



GENERAL CATALOGUE  
2016 - 2017



## THE COMPANY

Founded in 1992, Sistar was able to consolidate his position in the market becoming a point of reference for the Paint Dealers of various sectors and for Professional Users and for production companies in the market of Car-Body Shop, Nautic and Industry. Thanks to its deep knowledge of the sector, Sistar has always looking for innovative products and technology solutions in order to improve the quality of work of its customers. It is no coincidence that today Sistar is considered to be among the first Italian commercial companies in its market, strong of its market orientation, its dynamism, its dedication to meeting the needs of Consumer, for maximum attention to the Customer's needs, for the high level of service and, last but not least, to business ethics. **Sistar, people who think about your job.**



## THE COMMERCIAL ORGANIZATION

Sistar is among the main Italian trade organizations of the market, with a wide network of over 25 agents of covering the national territory and is present in 30 countries around the world. The sales force does not limit its intervention to pure commercial aspects, but tries to find solutions for the various technical issues. The internal organization is also composed of people who, thanks to specific skills, respond to the needs of the market.



## THE RANGE OF PRODUCTS

Sistar today presents the new Catalogue for a demanding and evolving market. A wide range of products carefully selected; from most electronic thickness gauges technology to the most basic paint filters, from chemical products to the articles for the safety protection. All products are to highest levels of performance to meet the needs of the professional End User and commercial needs of Dealer.



## THE PARTNERS

The strong work of Sistar allowed to enter into cooperation agreements with many companies for the distribution of articles and recognized brands in the world including: **Riwax, Kimberly-Clark, Honeywell, Mapa, BYK-Gardner, Testo, Elcometer, Sparco, Spray-Max, Fillone Technologie, DeVilbiss, DOW LINE - Glass Automotive System.**



## THE CUSTOMERS

Some important international Companies has chosen Sistar and its strategy oriented to quality and service. In Automotive field, Commercial Transport, Yachting and in Chemical and Paint sector.



## THE COMMUNICATION

Aware of the importance of communication with the market, Sistar has always paid particular attention to advertising, information and public relations, choosing specialized magazines most qualified and more important trade fairs in order to strengthen his own name and the knowledge of his products.

## THE CERTIFICATION

From July 2011 Sistar has been certified ISO 9001:2008 by the prestigious Certifying Body TÜV SÜD, important milestone in whose base is always continuous improvement and continuous striving for new projects.

## THE TECHNICAL CENTRE



Sistar, that in 2008 moved with offices and warehouse in new and wider seat of Desio, achieved a noteworthy Technical Center aimed at technical trials of products increasingly careful quality control and technical training sales network and customer feedback. The Technical Center has an area of preparation and polishing of the brand Nova Verta. With an area of 700 x 500 cm, with peg back filter intake and plenum, it's possible make any tests and demonstration, also to paint products in catalogue.

## THE SERVICES

Commercial office:

- Tel. (+39) 0362-367350 at your disposal from Monday to Friday from 8.30 to 12.30 and from 14.00 to 18.00
- Fax (+39) 0362-367352 Active 24-hour, 365 days per year
- Website: [www.sistar.it](http://www.sistar.it)
- E-mail:
  - [export@sistar.it](mailto:export@sistar.it) for your orders or requests of quotation
  - [logistic@sistar.it](mailto:logistic@sistar.it) for informations about delivery of goods and the status of orders
  - [accounting@sistar.it](mailto:accounting@sistar.it) for any request about invoices, payments, Bank variation, account statements.



# INDEX

## PRODUCTS RANGE

	DEKUPS by DEVILBISS *		4-5
	KIND BOX™ PAINTING SYSTEM *		6
	PAINT REFINISHING ANCILLARIES		7-14
	CLEANING AND POLISHING		15-26
	TECHNICAL ITEMS		27-36
	ABRASIVES		37-44
	MASKING AND SURFACE PROTECTION		45-52
	SPRAY LINE		53-70
	CHEMICAL PRODUCTS		71-76
	EQUIPMENTS		77-92
	MEASURING AND CONTROL INSTRUMENTS		93-98
	PERSONAL PROTECTION - DPI		99-124
	<b>DOW AUTOMOTIVE SYSTEMS *</b>		125-130
	<b>SPRAY MAX *</b>		131-148
	<b>RIWAX *</b>		149-176
	<b>DEVILBISS *</b> AUTOMOTIVE REFINISHING		177-190

The products range and features are subject to change at any time without notice. The informations are provided only for information and in good faith. They do not imply our responsibility due to many variables that can affect the proper use and performance of the products. Sistar doesn't take any responsibility for typographical errors or involuntary omissions.

\* PARTNERS FOR ITALIAN MARKET





PAGE 3-14

**DEKUPS** by DEVILBISS  
**KIND BOX™** PAINTING SYSTEM  
**PAINT REFINISHING** ANCILLARIES

BACK TO  
INDEX



## DeKUPS

### Disposable paint system cup for a highly professional painting

DeKups by DeVilbiss is the new disposable paint system cup, quick, easy and secure. The light, but strong liner of the cup compresses and provides a constant flow of product, increasing the quality of work and reducing the waste of paint; a plus not only economic, but also ecological. The reusable external conical lid is equipped with a quick coupling, safe and very strong, without tabs that can break, resistant against bumps and accidental falls.

#### Features:

- Wall-dispenser kit ready to use and protected from dust, contains 32 disposable liner and 32 internal lids
- Double Size: Standard = 710 ml and Mini = 265 ml
- Flexible, but very strong liner with flat and stable bottom when it is on the workbench
- Constant flow for a professional and exact painting
- The spraying from any slant, even upside down with gun
- Filters not welded to the lid, then reusable and washable if necessary
- 125 micron filters for water-soluble base and 200 micron for primer, surface coatings and solvent based transparent
- Light and strong adapter for spray-gun with quick spiral mechanism locking
- Plugs for the shake and temporary storage
- Funnel for filling of the liner without unscrewing the lid (in the absence of filtering disc)
- Flexible bottle for fast cleaning of the spray-gun



**DeKups Standard 710 ml**  
The most used for painting of full details and large surfaces.  
DPC-601 + DPC-606



**DeKups Mini 265 ml**  
Ideal for painting of small areas and Spot-Repair.  
DPC-602 + DPC-607

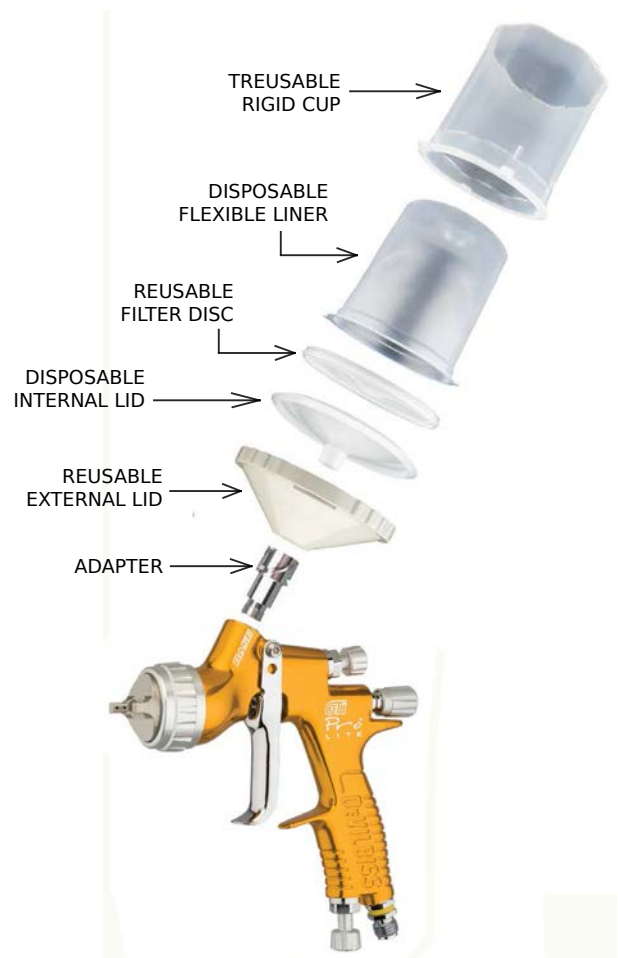



**128.DPC-42-K24**  
24 filter discs 125 micron  
for Dekups of 710 ml

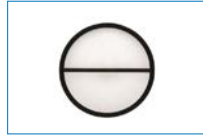

**128.DPC-66-K24**  
24 filter discs 200 micron  
for Dekups of 710 ml



**128.DPC-65-K24**  
24 filter discs 125 micron  
for Dekups of 265 ml

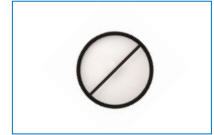

**128.DPC-67-K24**  
24 filter discs 200 micron  
for Dekups of 265 ml

**128.DPC-601 DeKups Standard**  
Kit of 710 ml with 32 disposable liner,  
32 disposable internal lids and  
10 closing plugs.

**128.DPC-602 DeKups Mini**  
Kit of 265 ml with 32 disposable liner,  
32 disposable internal lids and  
10 closing plugs.



**128.DPC-606 DeKups Standard**  
Disposable cup and lid for the system  
of 710 ml. Pack of 2 pcs.

**128.DPC-607 DeKups Mini**  
Reusable cup and lid for the system  
of 265 ml. Pack of 2 pcs.



**128.DPC-27-K10**  
10 filters 200 microns for  
spray-gun



**128.DPC-6-K10**  
10 closing caps for  
conservation



**128.DPC-22-K3**  
Funnel for topping (3 pcs.)



**128.DPC-8-K2**  
Cleaning bottle (2 pcs.)



**128.DPC-62-K10**  
Graduated guide 2:1 and 3:1 (10 pcs.)  
**128.DPC-63-K10**  
Graduated guide 4:1 and 5:1 (10 pcs.)



**128.DPC-10**  
Adapter for SATA NR 2/3000,  
RP, KLC, MCB, Jet serie 90,  
Sata 96.719



**128.DPC-11**  
Adapter for SATA NR95,  
Iwata LPH-400, W400LV



**128.DPC-13**  
Adapter for Sagola



**128.DPC-23**  
Adapter for SRI PRO  
(DeKups mini)



**128.DPC-502**  
Adapter for SATA Minijet QCC  
(DeKups mini)



**128.DPC-78**  
Adapter for Iwata Supernova



**128.DPC-80**  
Adapter for DeVilbiss, Binks,  
Sharpe



**128.DPC-504**  
Adapter for SATA QCC



**128.DPC-81**  
Adapter for SLG-620 DeVilbiss



**128.DPC-72**  
Adapter M12x1 for Airgunsa,  
Walcom, Asturo





## KIND-BOX™

Disposable or reusable system for preparation and application of paints, primers, enamels and clear coat, both solvent-based and water-based. It consists of a transparent graduated container with open-close valve on the bottom and of a conical cap inside of which is welded, depending on the model, a filter of 125 my for water-based products or 200 my for solvent-based products. When the paint is ready to use in the graduated container, the conical lid is screwed and, with a special adapter, the Kind-Box™ Painting System is connected directly to the spray gun with a push instead of original gravity cup. With the KIND-BOX™ Painting System is guaranteed a fast, clean and perfect work and the remaining paint can be kept a long time also taking care to close the lid with its conical cap.

### MINI KIND-BOX™ 325 ml

Code	Description
130.81200	Paint mixing cup and grey conical cap (without filter)
130.81300	Kit 325 ml included filter of 200 my welded on the grey conical cap
130.81400	Kit 325 ml included filter of 125 my welded on the black conical cap

### KIND-BOX™ 650 ml

Code	Description
130.80200	Paint mixing cup and grey conical cap (without filter)
130.80300	Kit 650 ml included filter of 200 my welded on the grey conical cap
130.80400	Kit 650 ml included filter of 125 my welded on the black conical cap

### MAXI KIND-BOX™ 900 ml

Code	Description
130.82200	Paint mixing cup and grey conical cap (without filter)
130.82300	Kit 900 ml included filter of 200 my welded on the grey conical cap
130.82400	Kit 900 ml included filter of 125 my welded on the yellow conical cap

### OPTIONAL FILTERS FOR KIND-BOX™

Black filter of 80 my ( $\pm$  5000 meshes) for transparent solvent-based paint.

Code	Size
130.80222	Ø 30 mm for Kind-Box 325 ml and 650 ml

Red filter of 125 my ( $\pm$ 2500 meshes) for water-based paint.

Code	Size
130.80207	Ø 80 mm for Kind-Box 650 ml and 900 ml
130.81207	Ø 65 mm for Kind-Box 325 ml

Green filter of 180 my ( $\pm$  1850 meshes) for solvent-based paint.

Code	Size
130.80208	Ø 80 mm for Kind-Box 650 ml and 900 ml
130.81208	Ø 65 mm for Kind-Box 325 ml



Grey conical cup 200 micron for solvent based paints



Black or yellow conical cup 125 micron for water based paints



## KIND-BOX™ ADAPTERS FOR SPRAY GUNS

Adapters to fix the system KIND-BOX™ on spray gun of all brands. Light and not vulnerable to attack by solvents and aggression from oxidation. The tightness is guaranteed thanks to the simple and fast hooking and unhooking system, without the need to use keys or screw.



<b>80210</b>	<b>80211</b>	<b>80212</b>	<b>80215</b>	<b>80217</b>	<b>80218</b>	<b>80224</b>	<b>80225</b>	<b>80226</b>	<b>80227</b>	<b>81215</b>
Sata Walcom SLG-620	De Vilbiss Binks Ani Graco	Sata Iwata T-Euro Asturo O.M. G-2005	Sata QCC	Asturo Mec Airgunsa Walcom (M12x1)	Sagola	Optima Asturo	Iwata AirGunsa Walcom Kremlin Walther Binks Ani Asturo Mec	Sagola X-Trene (M18x1,5)	De Vilbiss SRI-Pro/ SRI-Pro Lite	Sata Minijet 4 QCC Sata Minijet 3 (81210)

For models of spray guns, ask for a list apart. Special adapters for the spray-guns not included in the list are available on request.

## PAINT MIXING CUP

Disposable paper mixing cup for paint weight mixing. Do not use for volume paint mixing with graduated paddle. Suitable for water based paint and solvent based paint.

Code	Nominal content
<b>132.0010</b>	250 ml
<b>132.0015</b>	525 ml
<b>132.0012</b>	600 ml graduated
<b>132.0018</b>	750 ml
<b>132.0013</b>	Lid for 600 ml graduated



## PAINT MIXING CUP

Disposable transparent polypropylene mixing cup. Suitable for water based paint and solvent based paint.

Code	Total content
<b>132.0016</b>	600 ml



## PAINT MIXING CUP

Transparent graduated mixing cup made of polypropylene for solvent and water based paint mixing. Lid separately available.

Code	Total content	Lid code
<b>132.0052</b>	385 ml	<b>133.0158</b>
<b>132.0057</b>	750 ml	<b>133.0161</b>
<b>132.0062</b>	1400 ml	<b>133.0166</b>
<b>132.0071</b>	2300 ml	<b>133.0171</b>





**TOUCH-UP**

Polyethylene little bottle with brush for manual retouch. Suitable for solvent and water based paint. Metal sphere for an easier shake included.

Code	Content
<b>133.0605</b>	40 ml

**DOSING CARAFE**

Transparent graduated dosing carafe made in polypropylene. Suitable for solvent and water based paint.

Code	Content
<b>132.0031</b>	1000 ml
<b>132.0032</b>	2000 ml
<b>132.0033</b>	3000 ml
<b>132.0035</b>	5000 ml

**PAINT CUP**

White polypropylene cup. Suitable for solvent and water based paint. Lid separately available.

Code	Content	Lid code
<b>133.0101</b>	120 ml	<b>133.0151</b>
<b>133.0102</b>	280 ml	<b>133.0157</b>
<b>133.0104</b>	365 ml	<b>133.0157</b>
<b>133.0107</b>	520 ml	<b>133.0157</b>
<b>133.0110</b>	800 ml	<b>133.0160</b>
<b>133.0116</b>	1180 ml	<b>133.0163</b>
<b>133.0120</b>	1550 ml	<b>133.0165</b>

**SMALL BUCKET**

White bucket with handle and lid made in polypropylene. Suitable for solvent and water based paint.

Code	Content
<b>133.0045</b>	2,1 L
<b>133.0053</b>	3,5 L
<b>133.0060</b>	5,6 L
<b>133.0065</b>	11,1 L
<b>133.0066</b>	13,6 L
<b>133.0068</b>	26,0 L



## SMALL WASHING BASKET

White bucket with handle and lid made in polypropylene, 13,6 L capacity. It is used with Aercap dipping cleaner for spray-gun and spray equipment clening.



Code	Content
133.0090	13,6 L
307.0010	Cleaner Aercap

## DOSING BOTTLE

Dosing bottle with curved pipe made in polyethylene. Excellent for precise mixing during paint preparation.



Code	Content
133.0305	500 ml
133.0310	1000 ml

## SPRAY MATIC

Handy multi-function sprayer with manual charge.



Code	Content
785.4110	Fluid: 1,5 L - Total: 1,71 L

## SPRAYER

Pressure pump with spear sprayer suitable to vaporise the No-Dust Long Time on the floor of the spray booth.



Code	Content
133.1500	Fluid: 5 L - Total: 7,2 L.
310.5105	No-Dust



### GERSON ELITE

High quality paper paint strainer. Suitable for water based paint and solvent based paint.



Code	Micron	Color
131.0300	125 my	Blue
131.0302	190 my	Yellow
131.0304	260 my	Orange
131.0309	Dispenser	

### PAPER PAINT STRAINER

High quality paper paint strainer. Suitable for water based paint and solvent based paint.



Code	Description	Micron
131.0200	850 meshes	226 my Medium

### PLASTIC GRAVITY SPRAY-GUN FILTER

Gravity spray-gun filter for Sata, DeVilbiss, Iwata, Optima brands.

Code	Description	Micron
131.1000	Nylon net 600 meshes	280 my

Gravity spray-gun filter for Asturo Mec, Walmecc brands.

Code	Description	Micron
131.1010	Nylon net 2000 meshes	160 my

Gravity spray-gun filter for AOM, Azimonti brands.

Code	Description	Micron
131.1015	Nylon net 2000 meshes	160 my

### STEEL FILTER

Suction spray-gun filter.



Code	Description	Micron
131.1050	Filtering metal net 1000 meshes	190 my

## SUCTION SPRAY-GUN FILTER

Plastic filter for suction spray gun.



Code	Description	Micron
131.1100	2000 meshes	160 my
131.1110	5000 meshes	90 my
131.1120	10000 meshes	60 my

## FILTERING PLASTIC CUP

Filtering plastic cup with nylon net. Suitable for water based paint and solvent based paint.



Code	Description	Micron
131.0500	1000 meshes	190 my
131.0510	2000 meshes	160 my
131.0515	2500 meshes	120 my
131.0520	5000 meshes	90 my
131.0530	10000 meshes	60 my
131.0540	15000 meshes	45 my

## FILTERING PLASTIC CUP SUPER 90

Filtering plastic cup. Excellent for water based paint thanks to the wide filtering surface with Ø 90 mm.



Code	Description	Micron	Color
131.0550	2500 meshes	125 my	Green
131.0552	1000 meshes	190 my	Light blue
131.0554	600 meshes	280 my	White

## FILTERING NYLON NET

Size: 11x11 cm.



Code	Description	Micron
131.0600	5000 meshes	90 my
131.0605	2000 meshes	160 my
131.0607	2500 meshes	120 my
131.0610	10000 meshes	60 my

**COLOUR-MATCHING**

Colour matching metal plate, treated with acrylic primer. With black stripe for checking the quality of the covering paint power. Thickness: 0,15 mm.

Code	Color	Size
134.0135	White	130x90x0,15 mm
134.0140	Grey	130x90x0,15 mm

**COLOUR-MATCHING**

Colour matching paper card treated with special ink with no colour alteration. The version for water based paint has a special protection in order to avoid paint absorption.

Code	Description	Size
134.0200	For solvent based paints	100x130 mm
134.0205	For water based paints	100x130 mm

**STAR MIX™**

Reusable plastic mixing paddle. The special shape allow to mix the paint perfectly also in the bottom of the container.

Code	Description	Size
134.1012	Nylon Blue, semi-rigid	295x25 mm
134.1014	Polypropylene black, semi-flexible	295x25 mm

**RAPID-MIX™**

Plastic paint paddle for water based and solvent based paint products. Thanks to the special profile and holes it grants a quick and perfect mixing.



Code	Size
134.1016	Large 275x28 mm
134.1018	Small 200x20 mm

## ADHESIVE TAPE WITH CHESS FOR COVER TEST

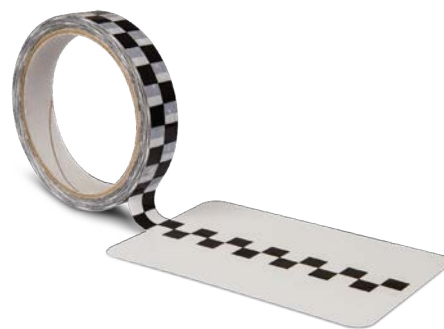

Code	Size
134.0100	Roll 19 mm x 30 m

## RECTIFIED BLADE

Stainless steel blade with smooth angles, perfectly rectified. Suitable for complete removing of paint defects.



Code	Size
138.0055	25x30x3 mm
138.0056	Magnetic sanding block

## SANDING BLOCK

Little hand sanding block, with magnetic for rectified blade and velcro connection for abrasive mini-discs.



Code	Description
138.0056	Magnetic sanding block
138.0055	Rectified blade
172.0535	Abrasive mini-disc with velcro

## SHIM-MASK by DEVILBISS

Stainless steel masking stencil to prevent rub-through when sanding or shaving minor surface imperfections. Ideal for: paint and lacquer runs, imperfections, minimising area when sanding paint-filled chips or scratches. Advantages: stainless steel 304 provides hardness for re-use, chemically etched shapes eliminates burred edges, choice of four stencil shapes.



Code	Pack
138.0070	Kit of 3 Shim-Mask 120x120 mm



### SPRAY-GUN CLEANING

Suitable for cleaning all types of spray guns. Brushes resistant to solvent and thinner for paint.

Code
138.5130



### PAINT DIRT REMOVER

Kit with 1 plastic pen holder with safety cap and 10 special needles. Excellent to remove dirt from the fresh paint work.

Code	Description
138.0051	Kit
138.0052	Blister



### MICRO-BRUSH

Manual touch up small brush with a thin cotton tip. 100 pieces Pack..

Code	Tip
136.0210	(A) Regular
136.0211	(B) Fine
136.0212	(C) Super fine



### RAZOR

Scraper steel blade holder with security lock. Excellent to remove glue, resin and any kind of dirt from surfaces.

Code	Size
138.0100	40x100 mm
138.0101	Blade spare parts - pack 100 pcs





PAGE 15-26

**CLEANING** AND POLISHING





### WHITE TACK CLOTH

White adhesive duster gauze for solvent based paint. Single pack.

Code	Cloth size
151.0020	82x47 cm



### TACK-RAGS GRAMOS

Non-woven cloth, semi-adhesive, white, duster with low content of resin. Ideal for water based paint. Single pack.

Code	Cloth size
151.0030	40x45 cm



### STAUB-FIX

The original "Made in Germany" adhesive duster cloth for solvent based paint and water based paint. Single pack.

Code	Description	Cloth size
151.0060	Staub-Fix Standard	80x50 cm
151.0065	Staub-Fix Hydro	80x50 cm



### DUPONT™ SONTARA® SPS

Special duster cloth for water-based and solvent based paints. Pack of 12 cloths.

Code	Cloth size
151.0055	38x43 cm

## BUMPER PREP PAD by DEVILBISS CLEAN

Abrasive fiber cloth impregnated with special detergent, specifically studied for the treatment of new bumpers without primers and for plastic parts. This product removes paint defects, cleans, degreases and makes the plastic surface mat in order to prepare for new painting. It's a disposable product, "all in one".

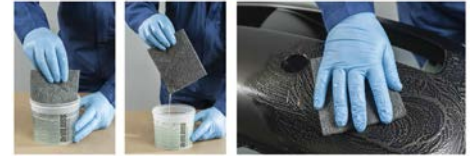

Code	Pack	Cloth size
151.0090	12 pcs.	140x115 mm

## DU PONT™ SONTARA® SPS

Turquoise non-woven cloth with embossed surface. Suitable to degrease surfaces with anti-silicone and cleaning products both solvent based and water based.



Code	Description	Cloth size
152.5040	Pack of 200 folded sheets	32,5x42 cm

## DU PONT™ SONTARA® SPS

Turquoise non-woven cloth with embossed surface. Suitable to degrease surfaces with anti-silicone and cleaning products both solvent based and water based.



Code	Description	Cloth size
152.5042	Roll of 250 sheets with central extraction	23x40 cm
152.5035	Wall dispenser for roll	

## DU PONT™ SONTARA EC® LIGHT

Turquoise non-woven cloth suitable for use with anti-silicone and cleaning products both solvent based and water based.



Code	Description	Cloth size
152.5050	Carton-box/dispenser of 300 sheets	30x42 cm



### KIMTECH PREP™

Embossed non-woven cloth made of polypropylene, blue. Ideal for use with anti-silicone and cleaning solvents. Great wet power. Available in three different packs.

Code	Description	Cloth size
152.7644	Brag-Box of 160 sheets	30x42 cm
152.7622	Folded in pack of 35 sheets	38x49 cm
152.7643	Roll of 500 sheets	38x34 cm



### KIMTECH WETTASK® SXX

Rechargeable wet cleaning system. White non-woven cloth, suitable for use with anti-silicone and cleaning solvents. After putting the fabric roll in the bucket, put the liquid inside in order to impregnate the cloth.

Code	Description	Cloth size
152.7764	Roll of 60 sheets with central extraction	29,5x29,5 cm
152.7921	HDPE bucket of 4,5 L	



### WYPALL X80 Steel Blue

Thick and very resistant cleaners for hard cleaning works, high absorbency in order to work better and faster. The structure HYDROKNIT is made using water jets which combine the soft paper fibers to the non-woven made of polypropylene. During the preparation of surface with solvents or during the cleaning of grease and oil slicks, these cloths are very good.

Code	Description	Cloth size
152.8373	Brag-Box of 160 sheets	31,8x42,7 cm





## WYPALL X60

Non-woven cloths made with unique and patented technology. Made of polypropylene and cellulose fibers, chlorine free, are durable and absorbent. Suitable to use dry or wet in all cleaning works with solvents and anti-silicone.



Code	Description	Cloth size	Color
152.8370	Brag Box of 200 sheets	31,7x42,6 cm	Light blue

## STAR-TEX

Light blue non-woven cloth, suitable for use with anti-silicone and cleaning solvents. Excellent absorption power. Pack of 100 sheets.

**NEW COLOUR  
TURQUOISE**



Code	Color	Cloth size
152.5020	Azure	37x50 cm
152.5022	Turquoise	37x50 cm

## CLEAN UP

Cleaning cloths impregnated with an effective detergent for cleaning surfaces, tools and equipments. It's particularly suitable for removing the sealant in excess used during the replacement of the plates and glasses. Used as hand-washing cloth, remove all kinds of hard dirt and odors without the use of soap and water due to its formula based on vegetable surfactants and durable non-woven fabric with a slightly rough side. It contains also antibacterial, glycerin and emollients to protect skin. Clean-Up can be used anywhere thanks to the pack portable and resealable to keep the damp cloths and sheltered from dust.



Code	Package	Pack.
152.5100	Barattolo-Dispenser da 70 panni 20x30 cm	6 pcs.





### SMOOTH PAPER TOWEL

Paper roll made of not recycled pure cellulose. Extra quality, double layer. Does not contain optical brighteners.

Code	Description	Color
575.8900	Roll of 800 sheets 26x38 cm - 3,5 kg about	White



### EMBOSSED PAPER TOWEL

Paper roll made of not recycled pure cellulose, double layer, extra quality. Embossed structure with honeycomb for better absorbency. Does not contain optical brighteners.

Code	Description	Color
575.8902	Roll of 800 sheets - 2,0 Kg about	White



### STAR-SOFT™

Cotton cloth for polishing. Excellent softness, low release of fibers and high absorbency. Acids and solvents resistant, silicone-free. Sterilized and also free of any particles that could damage the surface.

Code	Pack	Cloth size
161.5010	Pack of 200 sheets	40x40 cm



### STAR-WHITE™

White cotton for polishing, specific for car body-shops. Great softness and low release of fibers. Silicon free and also free of any particles that could damage the surface.

Code	Pack
161.5021	1 Kg
161.5023	0,5 Kg (pleated)
161.5025	5 Kg



## POLISOFT™

Non-woven cloth made of 100% perforated viscose. Very soft, is perfect for polishing any delicate surface in car-body Shop. Available in two convenient packs.

Code	Description	Cloth size
161.5030	Carton-box/dispenser of 550 sheets	30x40 cm
161.5032	Roll of 250 sheets	23x40 cm
152.5035	Wall dispenser for roll	



## RIWAX POLISHING CLOTH

Non-woven cloth soft for the use during the polishing. Central-extraction roll.

Code	Package
785.4065	Roll with 400 sheets 30x40 cm
785.1150	Wall dispenser



## DU PONT™ SONTARA® SPS POLISH CLOTH

Non-woven cloth very soft, excellent to polish the most delicate surfaces. Roll with central extraction.

Code	Pack	Cloth size
161.5052	Roll of 275 sheets	36,5x40 cm



## KIMTECH PREP™

Extra soft non-woven cloth, ideal for polishing use. Roll of 300 sheets with central extraction.

Code	Description	Cloth size
161.7212	Roll with carton-box	60x40 cm
161.7213	Roll with plastic bucket	60x40 cm





### MICROFIBER CLOTH

High-tech microfiber cloth. Ideal for cleaning delicate surfaces also without detergents. Excellent for polishing and removing halos on the body of vehicles. Collects and retains dust. Better absorbency, very resistant and durable even after several washes. Pack of 5 pieces.

Code	Cloth size	Color
161.8394	40x40 cm	Yellow
161.8395	40x40 cm	Light blue
161.8397	40x40 cm	Red
161.8396	40x40 cm	Green with smooth structure for glass



### WYPALL®

Soft microfiber cloth, ideal for cleaning and polishing delicate surfaces also without chemical detergents. It is also washable in washing machine up to 300 times. The green version with smooth structure is ideal for cleaning of glass and windshield.

Code	Cloth size	Color
161.5574.B	40x40 cm	Blue
161.5574.C	40x40 cm	Light blue



### CLEAN CLAY CLOTH

Microfiber cleaning cloth with one size made of abrasive clay for cleaning and polishing. It is used with RX20 or RX21 Spray Finish Riwax to remove dirty air pollution, industrial pollution, paint fumes, dust rust, bird droppings from car-body and painted surfaces. Used with Glas-Clar Riwax, it eliminates splashing tar, bitumen, resin. After use review with a microfiber cloth and the surface is thoroughly cleaned, free of any dirt and contamination, perfectly smooth and shiny.

Code	Size
785.5602	Cloth 30x32 cm, clay 26x28 cm about

### SMOOTH POLISHING SPONGE

Smooth polishing sponge, orange, medium density and hardness, suitable for polishing of painted surfaces with different abrasive pastes. Use with polishing machines with variable speed. Velcro connection.



Code	Size	Color
162.0160	ø 160 mm x 30 mm	Orange

## ASHLAR POLISHING SPONGE - ORANGE

Ashlar polishing sponge, orange, medium density and hardness, suitable for polishing of painted surfaces with different abrasive pastes. Use with polishing machines with variable speed. Velcro connection.

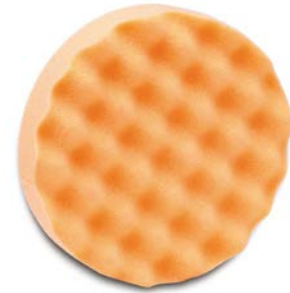

Code	Size	Color
162.0120	ø 180 mm	Orange
162.0129	ø 135 mm	Orange

## ASHLAR POLISHING SPONGE - BLUE

Ashlar polishing sponge, blue, soft. Suitable for polishing of painted surfaces with polishing abrasives pastes and finishing polish. Use with polishing machines with variable speed. Velcro connection.



Code	Size	Color
162.0127	ø 180 mm	Blue

## ASHLAR POLISHING SPONGE - BLACK

Ashlar polishing sponge, black, extra soft. Suitable for polishing of painted surfaces with finishing polish and protection wax. Use with polishing machines with variable speed. Velcro connection.



Code	Size	Color
162.0126	ø 180 mm	Black

## SMOOTH EXTRA-SOFT POLISHING SPONGE

Smooth polishing sponge with curved edge, extra soft, black. Suitable for the perfect polishing of painted surfaces with finishing polish and protection wax. Ideal for dark and delicate colors. Suitable for use with Orbitl polishing machine. Velcro connection.



Code	Size
162.0131	ø 160 mm

**V8 POLISHING SPONGE**

Orange polishing sponge with high density and hardness, suitable for polishing of painted surfaces with different abrasive pastes. Use with polishing machines with variable speed. Velcro connection.

Code	Size	Color
162.0105	ø 160 mm	Orange

**V65 POLISHING SPONGE**

Tobacco-colored polishing sponge with medium-soft density, suitable for polishing of painted surfaces with abrasive polishing pastes and finishing polish. Use with polishing machines with variable speed. Velcro connection.

Code	Size	Color
162.0155	ø 160 mm	Tobacco

**ASHLAR POLISHING MINI-SPONGE**

Ashlar polishing mini-sponge, orange, medium density and hardness. Suitable for polishing of painted surfaces with different abrasive pastes. Ideal for polishing of areas hard to access. Use with polishing machines with variable speed. Velcro connection.

Code	Size	Color
162.0128	ø 80 mm	Orange

**MINI-POLISHING SPONGE**

Mini-polishing sponge perfect for polishing of areas hard to access. Velcro connection.

Code	Description	Size	Color
162.0140	Medium	ø 80 mm	Orange
162.0146	Extra soft	ø 80 mm	Black

## PURE WOOL BONNET

Pure wool bonnet, suitable for polishing of painted surfaces with different abrasive pastes. Use with polishing machines with variable speed. Available with the classic connection with strings to be hooked on pad with code 164.0360.



Code	Size	Color
162.0201	ø 200 mm	White

## PURE WOOL DISC - WHITE

Pure wool disc, suitable for polishing of painted surfaces with different abrasive pastes. Use with polishing machines with variable speed. Available in different sizes. Velcro connection.



Code	Size	Color
162.0204	ø 150 mm	White
162.0206	ø 185 mm	
162.0207	ø 200 mm	

## PURE WOOL DISC - BLACK

Pure wool disc, suitable for polishing of painted surfaces with different abrasive pastes. Use with polishing machines with variable speed. Velcro connection.



Code	Size	Color
162.0205	ø 150 mm	Black
162.0209	ø 135 mm	

## MINI WOOL DISC

Mini wool disc, suitable for polishing of areas hard to access. Velcro connection.



Code	Size	Color
162.0210	ø 80 mm	White
162.0211	ø 80 mm	Black





### PREFORMED WOOL BONNET

Preformed wool bonnet, suitable for polishing of painted surfaces with different abrasive pastes. Use with polishing machines with variable speed. Available with velcro connection to be applied on pad with code 164.0345.

Code	Size
<b>162.0220</b>	ø 200 mm
<b>164.0345</b>	Pad ø 180 mm



### COMPRESSED AZELLA

Pure cellulose compressed sponge, 100% biodegradable. In contact with water it expands and is immediately ready for use.

Code	Size
<b>155.0073.CF</b>	Dry: 120x38x5 mm In use: 125x40x90 mm



### GROUND DISPENSER

Ground dispenser. Suitable for Rolls ø max. 60 cm, length max. 36 cm. Made of white metal.

Code	Size
<b>576.8920</b>	cm. 43x49x73 h.

### WALL DISPENSER

Wall dispenser. Suitable for Rolls ø max. 60 cm, length max. 36 cm. Made of white metal.

Code	Size
<b>576.8921</b>	cm. 39x34x24 h.



### TROLLEY

Big and strong trolley for paper or non-woven Rolls . With bag for rubbish.

Code	Size
<b>576.6155</b>	cm. 50x50x109 h.





PAGE 27-36

**TECHNICAL** ITEMS



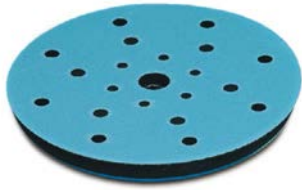

### UNIVERSAL SANDING PAD - 21 HOLES

Universal sanding pad with 21 holes (20+1 Central) with ducted suction. Suitable with all abrasive discs with 6, 7, 9, 15 and 21 holes. Thanks to double thread 5/16" and M8 can be placed on all Random Orbit Sanders. Velcro connection.

Code	Size	Thread
171.0406	ø 150 mm	5/16" e M8



### SANDING PAD - 15 HOLES

Sanding pad with 15 holes (14+1 Central) with ducted suction. Suitable with all abrasive discs with 6, 7, 9, 15 holes. Velcro connection.

Code	Size	Thread
171.0400	ø 150 mm	5/16"
171.0403		M8



### REINFORCED SANDING PAD - 15 HOLES

Reinforced sanding pad with 15 holes (14+1 Central) with ducted suction. Suitable with all abrasive discs with 6, 7, 9, 15 holes. Reinforced in the centre in order to prolong and intensify the use. Velcro connection.

Code	Size	Thread
171.0418	ø 150 mm	5/16"



### REINFORCED SANDING PAD - 6 HOLES

Reinforced sanding pad with 6 holes with direct suction. Reinforced in the centre in order to prolong and intensify the use. Suitable with all abrasive discs with 6 holes. Velcro connection.

Code	Size	Thread
171.0417	ø 150 mm	5/16"

## REINFORCED SANDING PAD WITHOUT HOLES

Reinforced sanding pad without holes. Reinforced in the centre in order to prolong and intensify the use. Suitable with all abrasive discs without holes or anti-halos polishing sponge with Random Orbitl Sanders. Velcro connection.



Code	Size	Thread
171.0419	ø 150 mm	5/16"

## SANDING PAD Ø 125 mm - 9 HOLES

Sanding pad Ø 125 mm with 9 holes (8+1 Central) with ducted suction. Can also be used with the Sander-polisher 471.0830. Velcro connection.



Code	Size	Thread
171.2018	ø 125 mm	5/16"

## MINI SANDING PAD

Mini-sanding pad for sanding and polishing the defects of paint. Velcro connection.

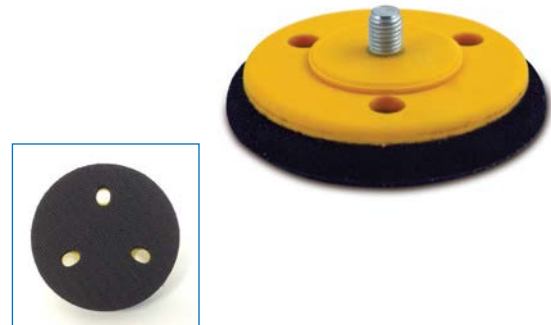

Code	Size	Thread
171.0305	ø 75 mm	5/16"

## MICRO SANDING PAD

Micro sanding pad made of rubber, Ø 30 mm, thread M10, available with velcro or adhesive connection. Usable with the mini random orbital angular sanding machine art. 471.0860 for sanding the defects of paint.



Code	Size	Thread	Description
171.0310	ø 30 mm	M10	Velcro connection
171.0315	ø 30 mm	M10	Adhesive connection



### SOFT ADAPTER

Soft adapter for sanding and polishing. Available with Ø 75 mm and 125 mm in order to match with their sanding pad. Velcro connection.

Code	Size	Thickness
171.0595	Ø 75 mm	10 mm
171.0597	Ø 125 mm	10 mm



### SEMI-RIGID ADAPTER

Universal semi-rigid adapter with 21 holes. To apply to sanding pad in order to make it softer. Velcro connection.

Code	Size	Thickness
171.0603	Ø 150 mm	6 mm



### SOFT ADAPTER

Universal soft adapter with 21 holes. To apply to sanding pad in order to make it softer. Velcro connection.

Code	Size	Thickness
171.0608	Ø 150 mm	10 mm



### VELCRO ADHESIVE ADAPTER

Velcro adhesive adapter to use instead of damaged velcro on sanding and polishing pads.

Code	Size	Holes
171.0610	Ø 150 mm	6
171.0611	Ø 150 mm	9
171.0612	Ø 150 mm	Without holes
171.0613	Ø 150 mm	15
171.0614	Ø 150 mm	21
171.0615	Ø 150 mm	7
171.0617	115x230 mm	Without holes

## SUCTION MANUAL SANDING BLOCK

Suction blocks for manual sanding with abrasive sheets with velcro connection. Available in 3 sizes. Velcro connection.

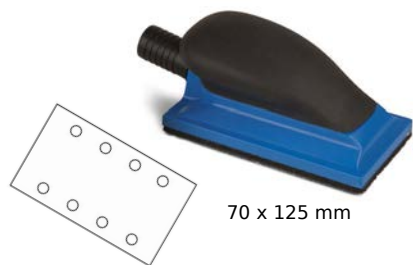

Code	Size	Holes
171.0200	70x125 mm	8
171.0202	70x420 mm	14
171.0205	115x230 mm	10

## MANUAL SANDING BLOCK - Ø 75 mm

Manual block for sanding with abrasive discs Ø 75 mm. The connection with micro-velcro allows the sanding also with fine grits in areas hard to access.



Code	Size
171.2001	Ø 75 mm

**MANUAL BLOCK FOR DISCS**

Manual block for sanding with abrasive discs Ø 150 mm. The connection with velcro on the sides allows the sanding with abrasive also in corners and in areas hard to access.



Code	Size
171.0535	75x150 mm

**MODULAR SANDING BLOCK**

Modular block made of rubber mousse for manual sanding. Thanks to rigid plate and the soft adapter can be obtained a block with different hardness for every need of sanding. Velcro connection.



Code	Size
171.0540	Block+plate+soft 70x125x49 mm (35+9+5 mm)
171.0541	Only block

**RUBBER SANDING BLOCK**

Rubber block for manual sanding wet.



Code	Size
171.0550	70x125 mm

**PLASTIC SANDING BLOCK**

Plastic block for manual sanding. The two springs on the sides stop the abrasive paper without velcro. Applying the velcro adapter 171.0617 can also be used with abrasive paper with velcro.



Code	Size
171.0555	105x215 mm



## MANUAL LITTLE SANDING BLOCK

Little block for manual sanding with abrasive mini-discs  $\varnothing$  35 mm. With a rigid side and a semi-rigid side with rubber support in addition to a soft adapter to get different hardnesses for every need of sanding.



Code	Description
171.0530	Velcro connection
171.0532	Adhesive connection
172.0555	Minidischetti adesivi $\varnothing$ 35 mm
172.0535	Minidischetti velcrati $\varnothing$ 35 mm

## WHEEL FOR REMOVING ADHESIVE STRIPE

Special rubber wheel suitable for removing adhesive and glue residues from surfaces without damaging the paint. Usable with the Eraser tool Cod. 471.0875. With the threaded adapter it can be mounted on a normal drill.



Code	Size	Thread
176.0500	$\varnothing$ 90 mm x 15 mm	5/16"
176.0501	Adapter for spin 5/16"	

## BLACK DRY-COAT

Spy-powder control for sanding. Apply the powder on putty and primer before sanding in order to highlight the non-sanded areas. Absolutely inert and compatible with all preparation products. Black color. The Kit has of 1 tampon to apply the spy-powder and 2 spy-powder bottles of 30 g.



Code	Description
173.8365	Buffer Kit + 2 refills of 30 g
173.8367	Spy-powder bottle of 30 g - Black

## ORANGE DRY-COAT

Spy-powder control for sanding. Apply the powder on putty and primer before sanding in order to highlight the non-sanded areas. Absolutely inert and compatible with all preparation products. The orange color improves the visibility on black and dark surfaces. The Kit has of 1 tampon to apply the spy-powder and 2 spy-powder bottles of 15 g.



Code	Description
173.8368	Buffer Kit + 2 refills of 15 g
173.8369	Spy-powder bottle of 15 g - Orange



### STEEL SPREADER

Steel spreader made of hardened C72-metal. Thickness: 0.25 mm. Available in 3 sizes.

Code	Size
<b>176.1520</b>	120x80 mm
<b>176.1521</b>	120x100 mm
<b>176.1522</b>	120x120 mm

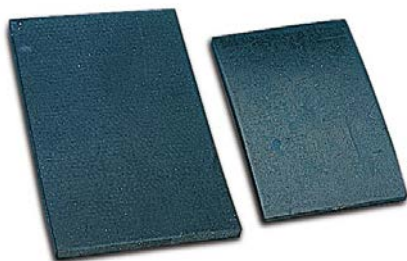

### RUBBER SPREADER

Spreader made of neoprene flexible rubber, solvents resistant. Thickness: 4 mm. Available in 2 sizes.

Code	Size
<b>176.1550</b>	76x50 mm
<b>176.1555</b>	100x60 mm



### METAL SPREADER

"Japanese" flexible metal spreaders. Set of 4 different sizes.

Code	Size
<b>176.1540</b>	50-80-100-120 mm x 125 mm



### PLASTIC SPREADER

Spreader made of polypropylene, solvents resistant. Rounded angles.

Code	Size
<b>176.1500</b>	115x80 mm

## PAD FOR WOOL BONNET

Semi-flexible rubber pad with support made of soft foam resin. Suitable for wool bonnet with strings.



Code	Size	Thread
164.0360	ø 180 mm	M14

## PAD FOR WOOL DISC

Rigid pad with support made of foam resin and rounded edges. Suitable for wool discs. Velcro connection.



Code	Size	Thread
164.0361	ø 185 mm	M14
164.0362	ø 150 mm	

## POLISHING PAD

Pad made of foam resin, suitable for wool discs and polishing pads. Velcro connection.

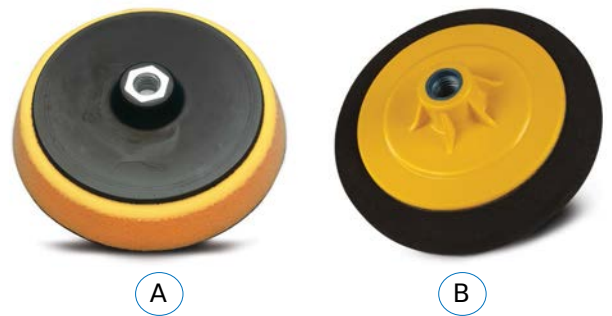

Code	Size	Thread
164.0363	Ⓐ ø 150 mm	M14
171.2015	Ⓑ ø 150 mm	5/8"

## MINI POLISHING PAD

Mini polishing pad made of resin, suitable for foam mini-pads and wool mini-discs. Velcro connection.



Code	Size	Thread
164.0365	Ⓐ ø 70 mm	M14
164.0366	Ⓑ ø 70 mm	5/8"



### PAD FOR PREFORMED BONNET

Rigid pad with rubber support, ideal for preformed wool bonnet or wool discs. Velcro connection.

Code	Size	Thread
164.0345	ø 180 mm	M14
162.0220	Cuffia in lana preformata	

### POLISHING SUPPORT

Rigid support-flange made of resin, yellow. Suitable for polishing pads. Velcro connection.



A



B

Code	Size	Thread
164.0373	ø 118 mm	M14
171.2033	ø 100 mm	5/8"

### RUBBER SANDING PAD

Semi-flexible rubber pad, suitable for polishing pads and wool discs. Velcro connection.



Code	Size	Thread
164.0350	ø 150 mm	M14
164.0352	ø 125 mm	

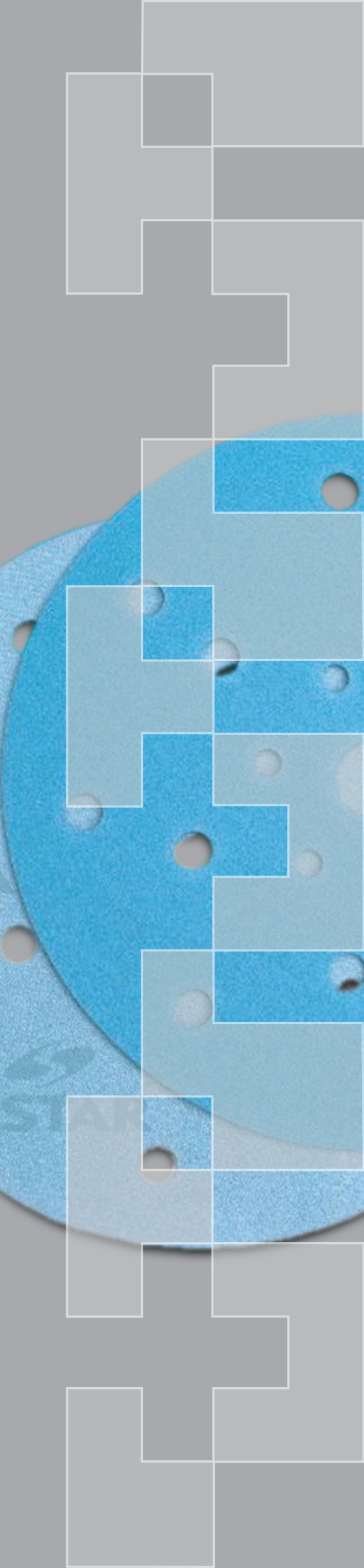

PAGE 37-44

**ABRASIVES**







## EXEL™

Abrasive of new concept with polyester film support. It can be used wet and dry, flexible, humidity resistant, completely plane, long duration and high performance. Suitable for the sanding of any finishing and preparation products.

**Abrasive:** aluminium oxide



**Substrate:** PE film

**Binder:** resin over resin

**Grain distribution:** open

**Powder free:** calcium stearate

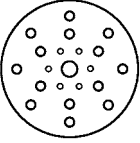
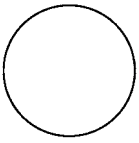
**Color:** light blue

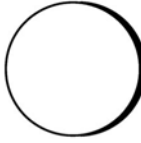
Grits	 <b>EXEL 21</b> discs Ø 150 mm 21 Holes Velcro connection			 <b>EXEL SF</b> discs Ø 150 mm Without holes Velcro connection			 <b>EXEL</b> discs Ø 75 mm Without holes Velcro connection			 <b>EXEL SOFT TOUCH</b> discs Ø 150 mm Velcro connection		
	Code	Code	Code	Package	Code	Package						
P60	172.0136.60			50 pcs.								
P80	172.0136.80		172.0140.80	50 pcs.								
P100	172.0136.100			100 pcs.								
P120	172.0136.120		172.0140.120	100 pcs.								
P150	172.0136.150		172.0140.150	100 pcs.								
P180	172.0136.180		172.0140.180	100 pcs.								
P220	172.0136.220		172.0140.220	100 pcs.								
P240	172.0136.240		172.0140.240	100 pcs.	172.0145.240 (21F)	20 pcs.						
P280	172.0136.280		172.0140.280	100 pcs.	172.0145.280 (21F)	20 pcs.						
P320	172.0136.320		172.0140.320	100 pcs.								
P360			172.0140.360	100 pcs.								
P400	172.0136.400		172.0140.400	100 pcs.	172.0145.400 (21F)	20 pcs.						
P500	172.0136.500			100 pcs.	172.0145.500 (21F)	20 pcs.						
P600	172.0136.600		172.0140.600	100 pcs.	172.0146.600 (SF)	20 pcs.						
P800	172.0136.800		172.0140.800	100 pcs.	172.0146.800 (SF)	20 pcs.						
P1000	172.0136.1000	172.0137.1000		100 pcs.	172.0146.1000 (SF)	20 pcs.						
P1200	172.0136.1200	172.0137.1200	172.0140.1200	100 pcs.	172.0146.1200 (SF)	20 pcs.						
P1500	172.0136.1500	172.0137.1500	172.0140.1500	100 pcs.								
P2000	172.0136.2000	172.0137.2000	172.0140.2000	100 pcs.	172.0146.2000 (SF)	20 pcs.						
P3000		172.0137.3000	172.0140.3000	100 pcs.	172.0146.3000 (SF)	20 pcs.						



**MASTER™**

High quality abrasive paper with high performance and long life. Available with discs Ø 150 mm, 15 holes and sheets in different size and holes, velcro connection. Suitable for sanding of any finishing and preparation products.

**Abrasive:** aluminium oxide  
**Substrate:** paper type B-C latex  
**Binder:** double phenolic resin  
**Grain distribution:** semi-open  
**Powder free:** calcium stearate  
**Color:** beige, inhomogeneous

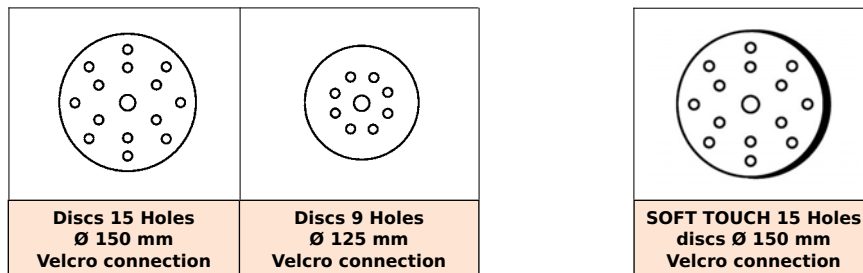

Grits	Code	Code	Package	Code	Package
P60	172.0120.60		50 pcs.		
P80	172.0120.80	172.2065.80	100 pcs.		
P100	172.0120.100	172.2065.100	100 pcs.		
P120	172.0120.120	172.2065.120	100 pcs.		
P150	172.0120.150	172.2065.150	100 pcs.		
P180	172.0120.180	172.2065.180	100 pcs.		
P220	172.0120.220	172.2065.220	100 pcs.		
P240	172.0120.240	172.2065.240	100 pcs.		
P280	172.0120.280	172.2065.280	100 pcs.		
P320	172.0120.320	172.2065.320	100 pcs.	172.0125.320	20 pcs.
P400	172.0120.400	172.2065.400	100 pcs.	172.0125.400	20 pcs.
P500	172.0120.500	172.2065.500	100 pcs.	172.0125.500	20 pcs.
P600	172.0120.600	172.2065.600	100 pcs.	172.0125.600	20 pcs.
P800	172.0120.800	172.2065.800	100 pcs.	172.0125.800	20 pcs.
P1000	172.0120.1000		100 pcs.	172.0125.1000	20 pcs.





## GOLD STAR™

Good quality abrasive paper for working with a good balance between price and quality. Discs Ø 150 mm, 15, 6 holes and without holes, velcro connection. Suitable for sanding of any finishing and preparation products in industry, automotive, nautic, building and wood market.

**Abrasive:** artificial corundum

**Substrate:** paper B-C

**Binder:** phenolic resin

**Grain distribution:** semi-open coat

**Powder free:** zinc stearate

**Color:** gold yellow

Grits							Package		
	Discs Ø 150 mm 15 Holes Velcro connection	Discs Ø 150 mm Without holes Velcro connection	Sheets 70x125 mm Without holes Velcro connection	Sheets 70x420 mm 14 Holes Velcro connection	Sheets 115x230 mm 10 Holes Velcro connection	Sheets 230x280 mm dry		Rolls 115 mm x 50 m dry	Rolls 115 mm x 25 m velcro connection
	Code	Code	Code	Code	Code	Code		Code	Code
P40	172.2160.40	172.2161.40		172.0225.40			50 pcs.		172.2170.40
P60	172.2160.60	172.2161.60		172.0225.60		172.2167.60	50 pcs.	172.2165.60	172.2170.60
P80	172.2160.80	172.2161.80	172.0220.80	172.0225.80	172.0235.80	172.2167.80	50 pcs.	172.2165.80	172.2170.80
P100	172.2160.100	172.2161.100		172.0225.100	172.0235.100	172.2167.100	100 pcs.	172.2165.100	172.2170.100
P120	172.2160.120	172.2161.120	172.0220.120	172.0225.120	172.0235.120	172.2167.120	100 pcs.	172.2165.120	172.2170.120
P150	172.2160.150	172.2161.150	172.0220.150	172.0225.150	172.0235.150	172.2167.150	100 pcs.	172.2165.150	172.2170.150
P180	172.2160.180	172.2161.180	172.0220.180	172.0225.180	172.0235.180	172.2167.180	100 pcs.	172.2165.180	172.2170.180
P220	172.2160.220	172.2161.220	172.0220.220	172.0225.220		172.2167.220	100 pcs.	172.2165.220	172.2170.220
P240	172.2160.240	172.2161.240	172.0220.240	172.0225.240	172.0235.240	172.2167.240	100 pcs.	172.2165.240	172.2170.240
P280	172.2160.280	172.2161.280	172.0220.280			172.2167.280	100 pcs.	172.2165.280	172.2170.280
P320	172.2160.320	172.2161.320	172.0220.320	172.0225.320	172.0235.320	172.2167.320	100 pcs.	172.2165.320	172.2170.320
P360	172.2160.360		172.0220.360		172.0235.360		100 pcs.		
P400	172.2160.400		172.0220.400	172.0225.400	172.0235.400	172.2167.400	100 pcs.	172.2165.400	172.2170.400
P500	172.2160.500		172.0220.500		172.0235.500		100 pcs.		
P600	172.2160.600				172.0235.600		100 pcs.		
P800	172.2160.800				172.0235.800		100 pcs.		
P1000	172.2160.1000						100 pcs.		

## PRO LINE RED GRIP

High performance abrasive paper with velcro connection. Abrasive made of corundum, binder of resin on glue, grain distribution semi-open, paper weight F. Suitable for sanding of any finishing and preparation products. Sectors of use: wood, industry, nautic, car-body Shop, metal and fiberglass.

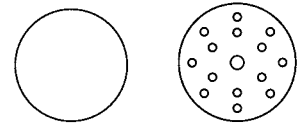

Code	Size	Grane	Package
172.0304	Discs ø 150 mm Without holes	P40-P60-P80	50 pcs.
		P100-P120-P150	100 pcs.
172.0302	Discs ø 150 mm 15 Holes	P40-P60-P80	50 pcs.
		P100-P120-P150	100 pcs.

## PRO LINE RED

Multi purpose abrasive paper, very flexible, high performances, rolls without velcro. Abrasive made of aluminium oxide, binder of double resin, grain distribution semi-close, latex paper weight C-D. Suitable for sanding dry and wet of preparation products. Sectors of use: wood, industry, nautic, automotive, plastic, metal.

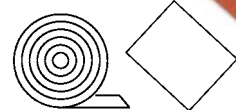

Code	Size	Grits	Package
172.0308	Roll 115 mm x 50 m	P40-P60-P80-P100 P120-P150-P180-P220	1 pcs.
172.0310	Sheets 230x280 mm	P120-P180-P240-P320	100 pcs.
172.0309	Mini roll 115 mm x 5 m	P60-P80-P100-P120-P150- P180-P220	1 pcs.

## MIRROR FINISH™

Fabric/Net abrasive made of silicon carbide with foam rubber support. Suitable for sanding wet with water and also dry, both with sanding machine and without. Available with fine grits in order to prepare the surfaces for touch-up and polishing. Velcro connection.



Code	Size	Grits	Package
172.0472	Discs Ø 150 mm Without holes	1000-2000 3000-4000	15 pcs.
172.0474	Mini discs Ø 75 mm Without holes	1000-2000 3000-4000	20 pcs.

## STAR LINE FINISH WP

Waterproof abrasive paper. Suitable for hand finishing wet of all painted products.



Code	Size	Grits	Package
172.2180	Sheets 230x280 mm	P400-P500-P600-P800 P1000-P1200-P1500- P2000-P2500	50 pcs.

## STAR LINE FIBER

Abrasive fiber made of non-woven, flexible. It can be used by both sides for sanding surfaces and areas hard to access. Available in two different Grits:

VF - very fine red (360) to create an excellent adhesion between painted products.

UF - ultra fine grey (1500) to make mat and rough painted surfaces.

**Abrasive:** aluminium oxide

**Support:** phenolic resin

**Binder:** resin over resin

**Grain distribution:** three-dimensional



### Rolls - 115 mm x 10 m

Code	Color	Grits	Package
172.0432	Red VF	360	1 pcs.
172.0434	Grey UF	1500	1 pcs.



### Sheets - 152 x 230 mm

Code	Color	Grits	Package
172.0442	Red VF	360	10 pcs.
172.0444	Grey UF	1500	10 pcs.



### Sheets - 280 x 115 mm

Code	Color	Grits	Package
172.0452	Red VF	360	10 pcs.
172.0454	Grey UF	1500	10 pcs.



### Discs - Ø 150 mm

Code	Color	Description	Grits	Package
172.0462	Red VF	With velcro connection	360	10 pcs.
172.0463	Red VF	Without velcro	360	10 pcs.
172.0464	Grey UF	With velcro connection	1500	10 pcs.
172.0465	Grey UF	Without velcro	1500	10 pcs.



## STAR LINE FOAM

Abrasive roll made of aluminium oxide, extremely flexible, with paper and sponge support. Suitable for manual sanding of any finishing and preparation products on irregular surfaces and areas hard to access.

Code	Size	Package
172.0410	Roll 115 mm x 25 m pretaglio a 125 mm	1 pcs.
Grits		
P150-P180-P220-P240-P280-P320-P400-P500-P600-P800		



## MASTER SOFT™

Abrasive paper of high quality and performances, soft roll, very flexible. Abrasive made of aluminium oxide on support of soft and latex paper, 4 mm. Suitable for manual sanding of preparation and finishing products on irregular surfaces and areas hard to access.

Code	Size	Package
172.0415	Roll 115 mm x 25 m pretaglio a 125 mm	1 pcs.
Grits		
P180-P220-P240-P280-P320-P400-P500-P600-P800-P1000		



## STAR LINE MINI ADHESIVE

Abrasive mini-disc Ø 32 mm, adhesive connection. Suitable for manual or with machine sanding of defects of paint. Pack of 100 pcs.

Code	Grits	Package
172.0555	P1200-P1500-P2000-P2500-P3000	100 pcs.



## STAR LINE MINI GRIP FINISHING

Abrasive mini-discs Ø 35 mm. Suitable for manual or with machine sanding of defects of paint. Use with the little block 171.0530 or 138.0056. Velcro connection.

Code	Grits	Package
172.0535	P1500-P2000-P2500-P3000	100 pcs.



### FIBER GLOBAL

Fiber abrasive, very resistant, perfect for matting the Cataphoresis treatment and hard paints. It is an innovative product and stands out for its great flexibility, efficiency and low price in relation to the duration and performance. Areas of application: Automotive, Metals, Composite Materials, Nautic Industry, Production of vehicles, Decoration, Building, Wood.

**Abrasive:** aluminium oxide (VF), silicon carbide (UF)

**Support:** non-woven Fabric

**Binder:** epoxy on resin

**Coating:** Three-dimensional

**Grits:** VF (360) UF (1500)

**Color:** Red (VF) Grey (UF)



Code	Color	Grits	Package
172.0470.360	Red VF	360	10 pcs.
172.0470.1500	Grey UF	1500	10 pcs.

### ABRASIVE BLOCKS

Abrasive blocks made of carbonaceous material, suitable to remove the defects on painted surfaces. Are used also in spot-repair to eliminate little dirt and drippings after painting and prepare the surface for polishing.

Il Kit comprende:

- 1 blocchetto abrasivo grana 800
- 1 blocchetto abrasivo grana 1500
- 1 blocchetto abrasivo grana 3000
- 1 spugnetta per manutenzione
- 1 barattolo con tappo a vite per contenere l'acqua.

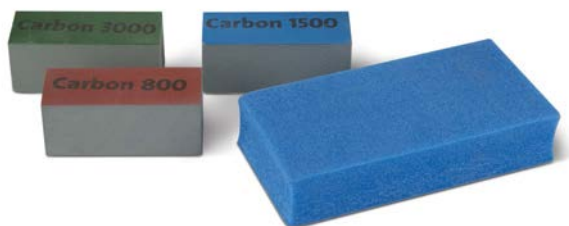

Code	Grits	Package
172.2500	800	10 pcs.
172.2501	1500	10 pcs.
172.2503	3000	10 pcs.
172.2505	Spugnetta per manutenzione	10 pcs.
172.2506.kit	Kit completo	1 pcs.



PAGE 45-52

**MASKING AND**  
SURFACE PROTECTION





### MASKING FILM WITH ADHESIVE TAPE

Masking Film with adhesive tape. Developed for quick masking of vehicles and for the protection of surfaces. With external corona treatment in order to guarantee the adhesion of the paint. Resistant up to 80° C.

Code	Size open film	Pack.
182.0550	35 cm x 22,5 m	20 pcs.
182.0551	60 cm x 22,5 m	16 pcs.
182.0552	90 cm x 22,5 m	16 pcs.
182.0553	120 cm x 22,5 m	16 pcs.
182.0554	180 cm x 22,5 m	15 pcs.
182.0556	260 cm x 22,5 m	12 pcs.
182.0558	360 cm x 22,5 m	14 pcs.
185.3006	Knife with protected blade	10 pcs.



### TRANSMASK

Masking Film in HDPE, solvents resistant and electrostatic. The external treated surface guarantees the adhesion of paint and over-spray. Folded sheet, roll h 95 cm.

Code	Size open film	Pack.
182.0145	400 cm x 150 m	1 pcs.
182.0149	400 cm x 300 m	1 pcs.
185.3006	Knife with protected blade	10 pcs.



### HY-MASK 160° C

Masking Film resistant to high temperatures up to 160° C, electrostatic and solvents resistant. Ideal for use in painting booths with infrared ray or radiant panels. The adhesion of the paint is guaranteed on both sides.

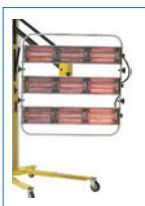

Code	Size open film	Pack.
182.0156	400 cm x 100 m	1 pcs.
185.3006	Knife with protected blade	10 pcs.

## HY-MASK 200°C

Transparent polyester film resistant to high temperatures, specifically designed to protect from the overspray the walls of booths equipped with endothermic radiant panels. Resistant up to 200 C.

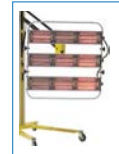

Code	Size open film	Pack.
182.0171	230 cm x 100 m	1 pcs.

## HIGH TRANSMASK

Masking Film in HDPE solvents resistant and electrostatic. The external treated surface guarantees the adhesion of paint and over-spray. Thank you to its height it is particularly suitable for big cars, SUVs, vans, commercial vehicles, Industrial car-body shop and Nautic Industry. Folded sheet, roll h 95 cm.



Code	Size open film	Pack.
182.0143	ca. 540 cm x 100 m	1 pcs.
185.3006	Knife with protected blade	10 pcs.



## SENSOR PARKING MASK

Removable adhesive specifically designed to protect and masking the parking sensors integrated in the bumpers during the sanding and painting operations. Thanks to this ingenious product is no necessary to remove the sensors by bumper avoiding malfunctions. Easy to apply and remove after work without leave trace. Resistant to sanding, solvents and paints. Size: diameter 18 mm. Resistant up to 180°C.

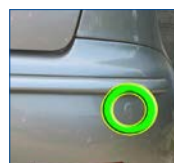

Code	Pack.
184.0920	300 pcs



**KRAFT MASKING PAPER**

Kraft paper of 40 g/m<sup>2</sup> with internal or external gloss. Havana-Brown color. Other sizes and weights available on request.

Internal gloss	External gloss		
Code	Code	Size	Roll/Pallet
181.0200.10	181.0201.10	h. 10 cm x 200 m	972 pcs.
181.0200.15	181.0201.15	h. 15 cm x 200 m	648 pcs.
181.0200.30	181.0201.30	h. 30 cm x 200 m	300 pcs.
181.0200.45	181.0201.45	h. 45 cm x 200 m	240 pcs.
181.0200.60	181.0201.60	h. 60 cm x 200 m	100 pcs.
181.0200.85	181.0201.85	h. 85 cm x 200 m	104 pcs.
181.0200.100	181.0201.100	h. 100 cm x 200 m	104 pcs.

**WHITE MASKING PAPER WITH POLYETHYLENE**

Plastified paper of 42 g/m<sup>2</sup> with internal or external gloss. White color. Recommended for water based products and professional paints. Other sizes and weights available on request.

Internal gloss	External gloss		
Code	Code	Size	Roll/Pallet
181.0150.10	181.0151.10	h. 10 cm x 150 m	972 pcs.
181.0150.15	181.0151.15	h. 15 cm x 150 m	648 pcs.
181.0150.30	181.0151.30	h. 30 cm x 150 m	350 pcs.
181.0150.45	181.0151.45	h. 45 cm x 150 m	280 pcs.
181.0150.60	181.0151.60	h. 60 cm x 150 m	100 pcs.
181.0150.85	181.0151.85	h. 85 cm x 150 m	104 pcs.
181.0150.100	181.0151.100	h. 100 cm x 150 m	104 pcs.

**MASKING TAPE 60°C**

Masking adhesive tape, suitable for building, industry, industrial car-body shop and repair of vehicles. Resistant up to 60° C for 60 minutes. Paper: semi-crepe. Adhesive: natural rubber.

Code	Size	Pack.
184.0030	19 mm x 50 m	96 pcs.
184.0031	25 mm x 50 m	72 pcs.
184.0032	30 mm x 50 m	60 pcs.
184.0033	38 mm x 50 m	48 pcs.
184.0034	50 mm x 50 m	36 pcs.

**CAR MASKING TAPE 80°C**

Masking adhesive tape for painting, resistant up to 80° C for 60 minutes. Paper: semi-crepe. Adhesive: natural rubber. Ideal for use in car-body shop.

Code	Size	Pack.
184.0020	19 mm x 50 m	96 pcs.
184.0022	25 mm x 50 m	72 pcs.
184.0023	30 mm x 50 m	60 pcs.
184.0024	38 mm x 50 m	48 pcs.
184.0026	50 mm x 50 m	36 pcs.
184.0027	75 mm x 50 m	24 pcs.
184.0028	100 mm x 50 m	18 pcs.

## AMERICAN TAPE

Multipurpose adhesive tape covered with a membrane of PE. Stands for resistance and elasticity. Ideal for external application.

NEW STRONGER  
ADHESIVE



Code	Size	Pack.
<b>184.0151</b>	50 mm x 50 m	30 pcs.

## BLUE MASKING TAPE - UV RESISTANT

Blue adhesive tape, UV-resistant, for professional masking in indoor and outdoor, away from water. Outside it resists for about 15 days. Suitable for a lot of sectors: automotive, industrial, nautic market, building, construction. Compatible with solvent based and water based paints. Adhesion also on irregular surfaces. Adhesive: acrylic.



Code	Size	Pack.
<b>184.0040</b>	19 mm x 50 m	96 pcs.
<b>184.0042</b>	25 mm x 50 m	72 pcs.
<b>184.0044</b>	38 mm x 50 m	48 pcs.
<b>184.0046</b>	50 mm x 50 m	36 pcs.

## BI-ADHESIVE TAPE

Bi-adhesive tape in PE with high adhesive power. Solvents, UV rays and high temperatures resistant. Suitable to fixing emblems and accessories inside and also outside.



Code	Size	Pack.
<b>184.0100</b>	6 mm x 10 m	20 pcs.
<b>184.0101</b>	9 mm x 10 m	12 pcs.
<b>184.0102</b>	12 mm x 10 m	10 pcs.
<b>184.0104</b>	19 mm x 10 m	6 pcs.

## OUTLINES TAPE

Plasticized tape made of PVC with India rubber adhesive. Specifically designed for fine lines, complex shapes and curves.



Code	Size	Pack.
<b>184.0109</b>	3 mm x 55 m	10 pcs.
<b>184.0110</b>	6 mm x 55 m	10 pcs.
<b>184.0111</b>	9 mm x 55 m	10 pcs.
<b>184.0112</b>	12 mm x 55 m	10 pcs.
<b>184.0113</b>	19 mm x 55 m	10 pcs.

**TRANSFER TAPE**

Contact bi-adhesive tape for sticking symbol and logo of vehicles. Thermal resistance of adhesive from -30° C up to +180° C. Temperature of application: from +15° C up to +35° C.

Code	Package	Pack.
<b>184.0160</b>	Busta da 10 strisce di 5 cm x 30 cm	10 pcs.

**PFF 1050**

Adhesive expanded film for internal protection of door panels. Water, humidity and dust resistant. Good absorbency. Thickness: 2.2 mm.

Code	Size	Pack.
<b>188.1050</b>	60 cm x 10 m	6 pcs.

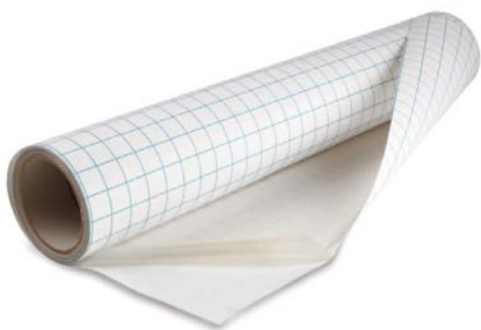
**PE 1055**

Repositionable adhesive film for internal protection of door panels and for blocking the broken glasses waiting replacement. Thickness: 100 my.

Code	Size	Pack.
<b>188.1055</b>	60 cm x 10 m	15 pcs.

**PROTECTIVE ADHESIVE FILM**

Adhesive film made of plastic, specifically designed for temporary protection of passage areas, workbench, balance, area near the tintometer and generally for all surfaces that you want to preserve from generic dirt and paint. Textured area non-slip. Thickness: about 240 micron. The adhesive is totally removed during the time. Light grey color.

Code	Size	Pack.
<b>188.1080</b>	60 cm x 25 m	1 pcs.

## EASY FOAM 950

No edge blending tape. An accurate and fast way to mask the structural lines and edges of the panels, does not stretch, it allows a perfect finish between old and new paint, eliminates not necessary processing steps.

Code	Size	Pack.
184.0950.5	20 mm x 5 m	10 pcs.
184.0950.25	20 mm x 25 m	6 pcs.



## EASY FOAM 970 EVOLUTION

Innovative foam to mask more easily the gaps between the doors, tailgate, bonnet, boot for prevent that paint comes into the cracks during painting. Thanks to the adhesive, unlike the classic foam, it is glued directly inside of the movable parts. After the closure the foam can be pressed and "adjusted"; that is impossible with the traditional foam. It allows to mask the 90% of the slots.

184.0970 - Oval profile 20x9 mm - Roll of 50 m

Code	Size	Pack.
184.0970	Oval profil 20 x 9 mm - Roll da 50 m	6 pcs.



## EASY FOAM 980

White foam tape compact and flexible for masking the cracks of vehicles between door panel and fender. Oval profile of 13x11 mm. Pack: box-dispenser of 50 m composed with 10 rolls of 5 m.

Code	Size	Pack.
184.0980	13 mm x 50 m	6 pcs.



## MAS-KING

Adhesive tape for masking of windshield, rear window and side window. Protects the seals during the painting removing the need to disassemble the glass. The product consists of an adhesive paper tape of 52 mm coupled with a strip of flexible polyester film of 12 mm, with pre-cut of 38 mm in order to facilitate the application in the curves and angles. Mas-king is resistant up to 70° C.

Code	Size	Pack.
184.0960	12 mm x 10 m	10 pcs.



### SOUND INSULATORS PANELS

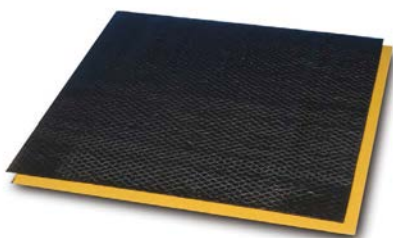

Adhesive Bitumen sheets excellent to isolate and insulate vehicles parts such as trunk, doors and under wheels. Available with smooth or embossed diamonds surface.

Code	Description	Size	Pack.
<b>188.1100</b>	Embossed diamond pattern	500x500x2 mm	10 pcs.
<b>188.1105</b>	Smooth		



### CAR COVER

Protective car cover made of internal non-woven and external protection in PE which makes it waterproof. The product had a rubber band along the whole base with 6 fixing hooks. Available in 2 sizes, for medium and large vehicles.

Code	Size	Pack.
<b>191.0102</b>	340x520 cm	5 pcs.
<b>191.0103</b>	380x630 cm	5 pcs.



### PROTECTIVE SEAT COVER

Protective seat cover made of white polyethylene. Universal size to fit all cars. Can be customized with the logo of the customer.

Code	Description	Pack.
<b>192.0202</b>	Roll h 60 cm of 50 sheets, with courtesy wrapper	2 pcs.
<b>192.0201</b>	Roll h 70 cm of 100 sheets in the dispenser	4 pcs.



### PROTECTIVE WHEEL COVER

Protective wheel cover made of non-woven Tyvek, with rubber band along the whole circumference. Reusable.

Code	Size	Package	Pack.
<b>191.0120</b>	80x80 cm	8 pcs.	40 pcs.





 **SISTAR**

PAGE 53-70

**SPRAY LINE**

BACK TO  
INDEX

# Fill-One



The new Fill-One machine is a pneumatic or manual filling machine for refillable pre-charged spray cans, for solvent and water based paint. Thanks to its patented Fill Cap the paint is transferred into the cans without making dirty the tanks because the cap is used instead of a normal tank. We can say that with the Fill-One you can change the colors (20 seconds for filling 1 can) without cleaning the machine. The safety during the use is due to the security front door.

## FILL-ONE PNEUMATIC MACHINE

Pneumatic filling machine to be connected to a compressor. It requires a pressure of 7-9 bar/130-100 psi. Completely automatic and safe, it is activated by closing the front door. It's complete of aluminium container for the cap of spray can. Very compact: only Ø 135 mm and 385 mm height. Can be fixed on the workbench or on metal base with the articles 406.0041. Can be fixed also to the wall with the support 406.0042; this solution is perfect for have the machine at handy without taking up space.

Code	Description
406.0040	Pneumatic machine
306.0245	Fill-Cap



Fill-Cap



## WALL SUPPORT

Painted strong metal bracket to fix the Fill-One pneumatic machine to the wall. With screw of 20 mm.

Code	Size
406.0042	145x170x200 mm

## AIR PRESSURE GAUGE

With support and quick connection for the tube of compressed air. Apply near the Fill-One pneumatic machine in a place clearly visible in order to have under control the pressure of 8 bar necessary for proper and safe working.

Code
406.0043



## WORK BENCH SUPPORT

Painted strong metal base to support the Fill-One pneumatic machine. With rubber feet and screw of 20 mm.

Code	Size
406.0041	300x400 mm

## FILL-ONE MANUAL MACHINE

Manual filling machine to fill the pre-charged spray cans with special Fill-Cap. This machine has the same benefits of pneumatic version but it works without the need for compressed air. Practical, simple, chip, transportable, usable everywhere. Suitable for Customers who do not have the compressor and don't have a high request of spray cans with special colors.

Code	Description
406.0038	Manual machine
306.0245	Fill-Cap



Fill-Cap



Completo di supporto

## 1K PRE-CHARGED SOLVENT BASED SPRAY

Pre-charged spray can containing solvent and propellant DME compatible with solvent based paints prepared with the tintometer. Spray can to complete with max.100 ml of paint by dealer through the correct filling machine. With adjustable spray head and professional atomization.



306.0245



306.0188

306.0190

306.0192

Code	Description	Content	Final content	Pack.
306.0190	For Fill-One system	300 ml	400 ml max	12 pcs.
306.0192	For traditional system			
306.0188	For traditional system	185 ml	250 ml max	12 pcs.
306.0245	Fill-Cap			12 pcs.
406.0040.250	Riser for mini spray can of 250 ml			1 pcs.

## 1K SPECIAL PRE-CHARGED SOLVENT BASED SPRAY

Pre-charged spray can with a different ratio of DME propellant gas and solvents. Can be used for solvent-based paints with different dilution compared to standard or pre-charged spray can 306.0190-306.0192. It's always recommended a preventive test.



306.0245



Code	Description	Content	Final content	Pack.
306.0196	Formula 1:5 – For traditional system	300 ml	400 ml max	12 pcs.
306.0245	Fill-Cap			12 pcs.

## 1K PRE-CHARGED SPRAY FOR SOLVENT BASED PAINT READY TO USE OR WATER BASED PAINT

Pre-charged spray can containing an additive and DME propellant gas compatible with solvent based paints ready to use or already diluted and with some water based paints (\*). Spray can of 250 ml to complete with 100-150 ml max. of paint by dealer through the correct filling machine. CFC-free. With adjustable spray head and professional atomization.

(\*). It's always recommended a preventive test.



306.0245



Code	Description	Content	Final content	Pack.
306.0197	For traditional system	250 ml	400 ml max	12 pcs.
306.0245	Fill-Cap			12 pcs.

## PRE-CHARGED SPRAY WITH CONVERTER FOR 2K PAINTS

Pre-charged spray can containing a converter to transform the 2K paints in 1K paints with air drying. Spray can of 325 ml to complete with 75-100 ml max of 2K solvent-based paint (without hardener) by dealer through the correct filling machine. CFC-free. With adjustable spray head and professional atomization.



306.0245



Code	Description	Content	Final content	Pack.
306.0195	For traditional system	325 ml	425 ml max	6 pcs.
306.0245	Fill-Cap			12 pcs.

The pre-filled spray cans can be customized with customers' logo.  
Ask for a free commercial offer.



## PRE-CHARGED FOR 1K WATER BASED SPRAY

Pre-charged spray can with propellants and additives compatible with water-based paints of the most important producers of tintometric systems for Car Refinish. Spray can to complete with 100 ml of water based paint by distributor through the correct filling machine. CFC-free. With adjustable spray head and professional atomization. The following pre-charged spray cans have been specially formulated for water based tintometric systems. Always follow the paint manufacturer's instructions (\*). To know the life of paint into the pre-charged spray can, consult the Technical Data Sheet of the paint.

**For the Fill-One System, use the Fill-Cap code: 306.0245**

Brand	Paint	Code Spray Max	Pack.
De Beer	Serie 900 Waterbase	750.680077	6 pcs.
DuPont	Cromax	750.680077	6 pcs.
DuPont	Cromax Pro	750.680355	6 pcs.
Glaserit	Serie 90	750.680077	6 pcs.
Helios	Mobihel Hydro	750.680075	6 pcs.
Lechler	Hydrofan	750.680078	6 pcs.
Lesonal	WB	750.961503	6 pcs.
MaxMeyer	AquaMax	750.680078	6 pcs.
Mipa	WBC	750.680075	6 pcs.
Nexa Autocolor	Aquabase	750.680078	6 pcs.
Palini	Hydropal	Available soon	6 pcs.
PPG	Envirobase	750.680078	6 pcs.
RM	Onyx HD	750.680077	6 pcs.
Sikkens	Autowave	750.680076	6 pcs.
Spies Hecker	PermaHyd	750.680075	6 pcs.
Spies Hecker	PermaHyd Hi-Tec 480	750.680355	6 pcs.
Standex	StandoHyd	750.680075	6 pcs.
Standex	StandoBluee	750.680355	6 pcs.



306.0245

(\*). Considering the number of colors and the variables involved, it's always recommended a preventive test.



## PROFESSIONAL SPRAY HEAD

Professional spray heads, with nozzles of different diameters for spraying the paint. Fixed round jet or adjustable jet in order to have a vertical or horizontal professional fan.

Code	Color	Description
306.0205	White/Grey	(A) White Sprayer, grey nozzle, large round jet for micaceous iron 360-055-032
306.0206	Black/White	(B) Black Sprayer, white nozzle, fine round jet 320-020-0200
306.0207	Red/Black	(C) Red Sprayer, black nozzle, medium adgustable fan 320-030 (1 mm)-025 FAN
306.0208	Black/Black	(D) Black Sprayer, black nozzle, fine adgustable fan 320-024 (0,6 mm)-025 FAN
306.0209	White/Yellow	(E) White Sprayer, yellow nozzle, extra-fine adgustable fan 320-024 FAN



## HANDLE SPRAY-GUN

Handle spray-gun for spray cans of 400 ml and for Preval of 94 ml. Allows better comfort during the use of spray cans and allows to do a more precise and professional work.

Code Sistar

306.0200

Code Spray-Max

750.746200

## SPRAY-PROTECT

Underbody protective. It makes a protection against gravel and stones in underbody, side sills and repaired panels. This product can be used to renew the original paints after repairs. It may be painted.



Code	Color	Package	Pack.
306.0105	Black	400 ml	12 pcs.

## 1K FILLER

Filler for sheet metal, aluminium and old paintwork. Suitable for superficial scratches and irregularities. High covering power. CFC-free. Sandable or repaintable after 30 minutes. VOC: IIB/(e) (840) 666 g/l. With adjustable spray head and professional atomization.



Code	Color	Package	Pack.
306.0120	Beige	400 ml	6 pcs.

## 1K PRIMER AND FILLER

Primer and filler for smooth surfaces, sheet metal, aluminium and old paintwork. Repaintable directly with all kinds of paints. CFC-free. VOC: IIB/(e) (840) 695 g/l. With adjustable spray head and professional atomization.



Code	Color	Package	Pack.
306.0110	Grey medium	400 ml	6 pcs.

## 1K SPRAY PUTTY

Filler Putty with high thickness and excellent fixing power. It can be used directly on sheet metal. CFC-free. Sandable after 60 minutes. VOC: IIB/(e) (840) 640 g/l. With adjustable spray head and professional atomization.



Code	Color	Package	Pack.
306.0115	Light grey	400 ml	6 pcs.





### BLACK SANDING CONTROL

Black spy spray for sanding. Apply light and homogeneous film on putty and primer before sanding in order to show not sanded areas. Compatible with all other preparation and finishing products. CFC-free. VOC: IIB/(e) (840) < 830g/L.

Code	Color	Package	Pack.
306.0117	Black	400 ml	6 pcs.



### PAINT FOR BRAKES

High quality silicone paint, resistant to heat up to 300°C, for the painting and protection of cars and motorcycles brakes. High coverage, durable gloss, weather-resistant, high surface hardness. Pigments do not contain lead, cadmium and chromium. It doesn't oxidize and doesn't turn in brown color.

Code	Color	Package	Pack.
306.2115	Red vivo glossy	400 ml	6 pcs.



### WHITE FOR PLATES

White high visibility paint with pearl effect, specially formulated for the maintenance of the plates of all vehicles (cars, trucks, buses, motorcycles, caravans, motorhomes, trailers). Fast drying in about 5 minutes. Low VOC content.

Code	Color	Package	Pack.
306.2117	White	400 ml	6 pcs.



### NITRO-ACRYLIC PAINT FOR INDUSTRIAL VEHICLES

Professional Nitro-acrylic paint. Special product for car-repair and for painting of metal and plastic surfaces. Particularly suitable for body of trucks. High coverage and durable gloss, non yellowing. Resistant to gasoline, alcohol, scratches and weathering after complete drying. Pigments do not contain lead, cadmium and chromium.

Code	Color	Package	Pack.
306.2120	Red chassis IC 105 Iveco	400 ml	6 pcs.
306.2121	Grey chassis IC 444 Iveco	400 ml	6 pcs.
306.2100.210	White Fiat 210	400 ml	6 pcs.
306.2100.249	White Fiat 249 Banchisa	400 ml	6 pcs.

**1K CLEAR COAT**

1K high gloss clearcoat (more than 90% gloss). It can be applied on all types of paints and enamels except those synthetic. UV rays resistant. CFC-free. VOC: IIB/(e) (840) 730 g/L. With adjustable spray head and professional atomization.

Code	Package	Pack.
306.0130	400 ml	6 pcs.



**2K CLEAR COAT**

2K high gloss clearcoat (more than 90% gloss). It can be applied on all types of paints and enamels except those synthetic. UV rays resistant. Spray can with catalyst inside to activate during the use. The paint must be used within 24 hours from activation of the catalyst. CFC-free. VOC: IIB/ (e) (840) < 830 g/L. With adjustable spray head and professional atomization.

Code	Package	Pack.
306.0133	250 ml	6 pcs.



**1K COLOUR & SANDING CHECK - Temporary clear coat**

1K COLOUR & SANDING CHECK spray acts as a temporary clear coat and it evaporates after a few minutes without leaving any residue and without damaging the paint or change the colour. 1K COLOUR & SANDING CHECK is suitable for the following application areas:

- 1.As test of sample colour simulating the effect of clear coat applied over two layer basecoats.
- 2.As quality and uniformity test of sanding. The sanded parts are temporarily converted into high-gloss areas making easily visible imperfections and irregularities.

Code	Color	Package	Pack.
306.0128	Transparent	400 ml	6 pcs.



**ALUMINIUM PAINT FOR WHEELS**

Professional nitro-acrylic paint. Special for wheels. Suitable for renew, beautify, protect from dirt and utilization wheels, rims, wheels covers of car, motorcycle and bicycle. High coverage, non-yellowing, alcohol resistant after 72 hours from application, scratches resistant after 4 days from application, gasoline resistant after 7 days from application. Weathering resistant. Rapid drying, 15-25 minutes, dry on touch. Pigments do not contain lead, cadmium and chromium.

Code	Color	Package	Pack.
306.2100.690	Wheels aluminium F690	400 ml	6 pcs.





### HIGH TEMPERATURE PAINT + 600°C

Silicone resins based paint resistant up to 600°C. High coverage, non-yellowing, lead-free. It allows quick and quality painting of engines, mufflers, exhaust pipes, etc.. Rapid drying: dry on touch in 10-12 minutes, completely dry in 24 hours at 20° C. CFC-free.

Code	Color	Package	Pack.
<b>306.2085.NO</b>	Black matt	400 ml	6 pcs.
<b>306.2085.AL</b>	Aluminium	400 ml	6 pcs.



### PLASTIC PAINT

It allows fast and high-quality painting also of large surfaces. Formulated with high content of pigments to maximize the speed, the application and the coverage. Can be used directly on plastic. Rapid drying. CFC-free. VOC: IIB / (s) (840) < 682 g/L. With adjustable spray head and professional atomization.

Code	Color	Package	Pack.
<b>306.0140</b>	Dark grey	400 ml	12 pcs.
<b>306.0142</b>	Black	400 ml	12 pcs.



### SPRAY-PLAST

Textured paint for plastic parts. It allows fast and high-quality painting also of large surfaces. Formulated with high content of pigments to maximize the speed, the application and the coverage. Usable directly on plastic parts. Rapid drying. CFC-free. With adjustable spray head and professional atomization.

Code	Color	Package	Pack.
<b>306.0152</b>	Black	400 ml	12 pcs.
<b>306.0153</b>	Dark grey	400 ml	12 pcs.

## UNIVERSAL MULTIFUNCTIONAL LUBRICANT

Universal multifunctional synthetic lubricant for all moving parts. Penetrating and unlocking for nuts, bolts, gears and mechanisms blocked by rust. Protects and inhibits corrosion of the treated parts. Excellent adhesion to metal. Water-resistant and durable even in extreme conditions.

Code	Package	Pack.
306.0509	400 ml	12 pcs.



## UNLOCK & UNSCREW UNBLOCKING

Penetrating synthetic spray with a high solvent and releasing power. It facilitates the releasing process of nuts, bolts, joints, threads, hinges and all other mechanical parts affected by rust and oxidation. It also leaves a lasting water-proof and water repellent protective film.

Code	Package	Pack.
306.0511	400 ml	12 pcs.



## NAUTICAL WHITE LITHIUM GREASE

White lithium and titanium grease, highly waterproof, specifically for the marine industry and for all uses in contact with water. Ideal for lubricating gears of marine engines, mechanical parts of motor boats and sailing, fishing and diving equipment, couplings, joints, pins, transmissions, hinges, etc. Not melts, stable for long time, acts perfectly at temperatures from -20°C up to +120°C. Resistant to corrosion of salt and sweet water and to the action of weathering elements.

Code	Package	Pack.
306.0513	400 ml	12 pcs.



## MULTIPURPOSE GREASE LUBRICANT

A compound of high quality saponified greases. Grease with a wide spectrum of uses, good chemical stability, water repellent and adhesive. Protects against water and is perfectly stable and resistant in brine and dirty atmospheres. Resists to acid and basic solution and atmospheric corrosion. Ideal for lubricating bearings, bushes, hubs kingpins, guides and for all use with motor vehicles, farming and industrial machinery.

Code	Package	Pack.
306.0514	400 ml	12 pcs.





### SILICONE BASED OIL

Pure silicone based oil solution with anti-adhesive qualities which owing to its separating and lubricating properties, can be used on a variety of materials. Non-greasy, it gives a good water repellency on treated materials preventing the accumulation of electrostatic charges. It is effective as polishing and protective on plastic parts. Maintains the elastic seals and free from cracks increasing tightness and durability.

Code	Package	Pack.
306.0516	400 ml	12 pcs.



### VASELINE OIL

Vaseline oil with high degree of purity, specially designed for applications that require periodic maintenance and lubrication without grease stain. Suitable for lubricating machinery, equipment and delicate gear. Its special formula also acts as a lasting protective power. Doesn't contain solvents and does not damage rubber and plastic. Odorless and colorless.

Code	Package	Pack.
306.0517	400 ml	12 pcs.



### ELECTRICAL AND ELECTRONIC CONTACT CLEANER

Specifically designed for deep cleaning of electrical, electronic and electromagnetic contacts. Immediately removes moisture, dirt, grease and oxidation leaving the surface perfectly clean and degreased. Avoid use on delicate materials and on surface can attacked from solvents.

Code	Package	Pack.
306.0520	400 ml	12 pcs.



### UNIVERSAL NEOPRENE GLUE

Permanent contact neoprene adhesive, very tenacious, particularly suited for bonding rubber, vinyl and synthetic materials, plastics, cloth, felt, leather, wood, paper, cardboard, laminates, glass, ceramics, metal. Spray an adequate amount on both surfaces to be bonded, wait for evaporation of solvent then join the parts using heavy pressure.

Code	Package	Pack.
306.0522	400 ml	12 pcs.



## STICKERS AND GLUE REMOVER

Solution solvents and synthetic polymers based with rapid action in the melt glues and a lot of kinds of adhesives. If the solution is sprayed in vertical position does not drip. The adhesive label or glued part comes off in a few minutes. On labels with film, in order to reduce waiting times, eliminate the plastic film.



Code	Package	Pack.
306.0524	200 ml	12 pcs.

## HIGH PRESSURE DUST CLEANER

High pressure Dust Cleaner is made of compressed flammable gas. Immediately removes all dust from inaccessible areas and delicate mechanisms such as watches, computers, keyboards, electrical and electronic equipment, lenses and photographic lenses, precision mechanics, miniature gears, modeling, etc. Do not use on electrical equipment on or energized.



Code	Package	Pack.
306.0527	400 ml	12 pcs.

## ALL CLEAN TOP

Universal foam Cleaner to remove quickly all kinds of dirt from painted surfaces, windshield, headlights, crystals, metal parts, plastic parts both in the automotive market and for private use. Also suitable for ceramic, tiles, glass and washable surfaces of all types. Does not contain abrasive substances, does not leave streaks and does not drip.



Code	Package	Pack.
306.0500	500 ml	12 pcs.

## PREVAL SPRAY GUN

The "portable spray gun." It's ideal to spray paint already diluted and many other liquid products in any place, free from compressed air and electricity. It's enough to put the painting products in the glass container, screw the spray can and spray, following the instructions for use. The Complete Kit consists of 1 glass container of 200 ml, 1 propellant gas cartridge of 94 ml with tube and 1 screw cap.



Code	Description
306.1215	Kit completo
306.1216	Contentitore in vetro di ricambio da 200 ml
306.1217	Cartridge Gas di ricambio da 94 ml + pescante





### HIGH QUALITY ACRYLIC PAINT H.S. RAL COLORS

High quality acrylic paint, high solids, to decorate and protect internal and external surfaces. Dry on touch in 10 minutes, completely dry in 24 hours. Repaintable in any time. With special self-cleaning valve. Suitable for surfaces and objects made of metal, aluminium, wood, wicker, glass, cardboard, stone, terracotta and some types of plastic (ABS and PVC). Not suitable for polystyrene surfaces.

Code	Package	Pack.
306.2000.xxxx (RAL)	400 ml	6 pcs.



### HIGH QUALITY ACRYLIC CLEAR COAT H.S.

High quality acrylic paint, high solids, to decorate and protect internal and external surfaces. Dry on touch in 10 minutes, completely dry in 24 hours. Repaintable in any time. With special self-cleaning valve. Suitable for surfaces and objects made of metal, aluminium, wood, wicker, glass, cardboard, stone, terracotta and some types of plastic (ABS and PVC). Not suitable for polystyrene surfaces.

Code	Versione	Package	Pack.
306.2001.LU	Transparent Glossy	400 ml	6 pcs.
306.2001.OP	Transparent Matt	400 ml	6 pcs.



### DISPLAY FOR SISTAR SPRAY LINE

Display of new concept and elegant design. Made of white laminated wood, with 4 swivel wheels to move it easily. With 6 shelves to expose 42 different articles (3 shelves of 7x4 cm + 3 shelves of 7x5 cm). It can accommodate up to 189 spray cans. With 2 side pockets for brochures.

Code	Size
406.0100	L54 x P36 x H190 cm

RAL COLORS\*

					
<b>RAL 1001</b> <i>Beige</i>	<b>RAL 1003</b> <i>Signal yellow</i>	<b>RAL 1004</b> <i>Golden yellow</i>	<b>RAL 1007</b> <i>Daffodil yellow</i>	<b>RAL 1013</b> <i>Oyster white</i>	<b>RAL 1015</b> <i>Light ivory</i>
					
<b>RAL 1018</b> <i>Zinc yellow</i>	<b>RAL 1021</b> <i>Rape yellow</i>	<b>RAL 1023</b> <i>Traffic yellow</i>	<b>RAL 1033</b> <i>Dahlia yellow</i>	<b>RAL 2000</b> <i>Yellow orange</i>	<b>RAL 2002</b> <i>Vermilion</i>
					
<b>RAL 2004</b> <i>Pure orange</i>	<b>RAL 2008</b> <i>Bright red orange</i>	<b>RAL 2009</b> <i>Traffic orange</i>	<b>RAL 3000</b> <i>Flame red</i>	<b>RAL 3001</b> <i>Signal red</i>	<b>RAL 3002</b> <i>Carmine red</i>
					
<b>RAL 3003</b> <i>Ruby red</i>	<b>RAL 3020</b> <i>Traffic red</i>	<b>RAL 5002</b> <i>Ultramarine blue</i>	<b>RAL 5003</b> <i>Sapphire blue</i>	<b>RAL 5005</b> <i>Signal blue</i>	<b>RAL 5007</b> <i>Brilliant blue</i>
					
<b>RAL 5009</b> <i>Azure blue</i>	<b>RAL 5010</b> <i>Gentian blue</i>	<b>RAL 5012</b> <i>Light blue</i>	<b>RAL 5013</b> <i>Cobalt blue</i>	<b>RAL 5015</b> <i>Sky blue</i>	<b>RAL 5017</b> <i>Traffic blue</i>
					
<b>RAL 5018</b> <i>Turquoise blue</i>	<b>RAL 6001</b> <i>Emerald green</i>	<b>RAL 6002</b> <i>Leaf green</i>	<b>RAL 6005</b> <i>Moss green</i>	<b>RAL 6011</b> <i>Reseda green</i>	<b>RAL 6018</b> <i>Yellow green</i>
					
<b>RAL 6021</b> <i>Pale green</i>	<b>RAL 6029</b> <i>Mint green</i>	<b>RAL 7000</b> <i>Squirrel grey</i>	<b>RAL 7001</b> <i>Silver grey</i>	<b>RAL 7016</b> <i>Anthracite grey</i>	<b>RAL 7021</b> <i>Black grey</i>
					
<b>RAL 7021</b> <i>Black grey semi-matt 25 gloss</i>	<b>RAL 7024</b> <i>Graphite grey</i>	<b>RAL 7030</b> <i>Stone grey</i>	<b>RAL 7031</b> <i>Blue grey</i>	<b>RAL 7032</b> <i>Pebble grey</i>	<b>RAL 7035</b> <i>Light grey</i>
					
<b>RAL 7037</b> <i>Dusty grey</i>	<b>RAL 7038</b> <i>Agate grey</i>	<b>RAL 7040</b> <i>Window grey</i>	<b>RAL 7042</b> <i>Traffic grey A</i>	<b>RAL 7044</b> <i>Silk grey</i>	<b>RAL 8011</b> <i>Nut brown</i>
					
<b>RAL 8014</b> <i>Sepia brown</i>	<b>RAL 8017</b> <i>Chocolate brown</i>	<b>RAL 8019</b> <i>Grey brown</i>	<b>RAL 9001</b> <i>Cream</i>	<b>RAL 9002</b> <i>Grey white</i>	<b>RAL 9003</b> <i>Signal white</i>
					
<b>RAL 9005</b> <i>Jet black</i>	<b>RAL 9005</b> <i>Black matt 5 gloss</i>	<b>RAL 9005</b> <i>Black semi-matt 25 gloss</i>	<b>RAL 9006</b> <i>White aluminium</i>	<b>RAL 9007</b> <i>Grey aluminium</i>	<b>RAL 9010</b> <i>Pure white</i>
					
<b>RAL 9010</b> <i>White matt</i>	<b>RAL 9016</b> <i>Traffic white</i>				

\* Colors are obtained with a printing method and therefore purely indicative. For the RAL colors the evidence is the color match collection. The unavailable RAL colors will be available on request.





### ANTI-RUSTY FILLER

Acrylic anti-rusty filler for internal and external areas. Suitable for protection of all surfaces subject to corrosion. Zinc-based filler, high-coverage, non-yellowing. Applicable directly on rust, weathering resistant, good corrosion power. Rapid drying: 15-25 minutes, dry on touch.

Code	Color	Package	Pack.
306.2010.GR	Grey	400 ml	6 pcs.



### RUST CONVERTER

Rust converter, it can transform with chemical reaction the rust into an inert compound overpaintable and stops the formation of rust, eliminates the operation of cleaning of rust from surfaces. It has the same anti-corrosion properties of conventional anti-rust. Apply directly over rust. Overpaintable with spray paints after 24-30 hours minimum and within 48 hours without sanding.

Code	Color	Package	Pack.
306.2012	Ambrato, Black dopo reazione chimica	400 ml	6 pcs.



### PURE ZINC

Professional Zinc paint for internal and external areas made with pure zinc powder and phosphate of zinc. For the protection of all surfaces from the corrosion. Suitable for tanks, pylons, railings, etc. Suitable even after operations of threading, cutting or soldering to restore the resistance at the corrosion. High covering, non-yellowing, applicable directly on rust, atmospheric agents resistant, high anti-corrosive power. Rapid drying: 15-25 minutes, dry on touch.

Code	Color	Package	Pack.
306.2015	Grey	400 ml	6 pcs.

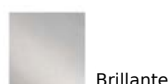

Brillante



Matt

### TRANSPARENT ANTI-RUSTY

Anti-rusty Transparent Paint for internal and external areas. Suitable for the protection of metallic surfaces and objects from corrosion, ageing and oxidation. Formulated with Phosphate of Zinc and inhibitors of rust. Non-yellowing, atmospheric agents resistant. Rapid drying: 15-25 minutes, dry on touch.

Code	Color	Package	Pack.
306.2020.BR	Transparent brillante	400 ml	6 pcs.
306.2020.OP	Transparent matt	400 ml	6 pcs.

## CAR & MOTORBYKE 1K CLEAR COAT

Nitro-acrylic transparent paint for cars and motorbike. Suitable for body of painted cars, motorbike and bike. Non-yellowing, alcohol resistant after 72 hours from the application, scratch resistant after 4 days from the application, gasoline resistant after 7 days from the application, atmospheric agents resistant. Rapid drying: 15-25 minutes, dry on touch.



Code	Color	Package	Pack.
306.2110	Transparent	400 ml	6 pcs.

## PLASTIC & METAL PRIMER

Acrylic primer for internal and external areas. Adhesion Primer for all types of plastic. Made of acrylic resins and special additives for adhesion. Suitable even for steel, aluminium, brass, copper and bronze surfaces. It can improve the adhesion of finishing paints. It's elastic. Rapid drying: 15-25 minutes, dry on touch.



Code	Color	Package	Pack.
306.2025	Transparent	400 ml	6 pcs.

## METALLIC PAINT

Pure acrylic paint for internal and external areas with metallic effect. Suitable for decoration and protection of all surfaces and objects. It contains fine metallic pigments. High covering, non-yellowing, UV and atmospheric agents resistant. Rapid drying: 15-25 minutes, dry on touch. The pigments are free from lead, cadmium and chromium.



Silver



Black



Viola



Green



Blu



Code	Color	Package	Pack.
306.2060.AR	Silver	400 ml	6 pcs.
306.2060.NE	Black	400 ml	6 pcs.
306.2060.VI	Violet	400 ml	6 pcs.
306.2060.VE	Green	400 ml	6 pcs.
306.2060.BL	Blue	400 ml	6 pcs.





Grey Silver



Grey Grafite



Black

### OLD IRON PAINT

Acrylic paint with highly decorative effects, such as sandblaster iron. Indicated for all metal surfaces, without need of anti-rust, for wood and plastic.

Code	Color	Package	Pack.
<b>306.2050.AR</b>	Grey Silver	400 ml	6 pcs.
<b>306.2050.GR</b>	Grey graphite	400 ml	6 pcs.
<b>306.2050.NE</b>	Black	400 ml	6 pcs.



Yellow



Green



Red



Fucsia

### FLUORESCENT PAINT

Pure acrylic paint for internal and external areas, fluorescent effect. For decoration and protection of all surfaces and objects that need visibility even at distance or with low brightness. High visibility up to 150 m, non-yellowing, UV and atmospheric agents resistant. Rapid drying: 15-25 minutes, dry on touch. The pigments are free from lead, cadmium and chromium.

Code	Color	Package	Pack.
<b>306.2032.GI</b>	Yellow	400 ml	6 pcs.
<b>306.2032.VE</b>	Green	400 ml	6 pcs.
<b>306.2032.RO</b>	Red	400 ml	6 pcs.
<b>306.2032.FU</b>	Fucsia	400 ml	6 pcs.



### PHOSPHORESCENT PAINT

Paint highly phosphorescent and visible in the dark. Suitable for all supports and sites with low brightness and visibility (steps, switches, signalings, etc.) Suitable even for particular domestic decorations and for bikes, moto, scooter, cars. High covering, high visibility at darkness, it can recharge autonomously with safety special light. Rapid drying: 15-25 minutes, dry on touch. The pigments are free from lead, cadmium and chromium.

Code	Color	Package	Pack.
<b>306.2034.GI</b>	Yellow phosphorescent	400 ml	6 pcs.

**“LEAFING” METALLIC PAINT**

Metallic paint for decoration and protection of all surfaces and objects to give them chromium plated precious look. Usable on brass, stone, earthenware, aluminium, copper, bronze, wood, etc. High covering, non-yellowing, specific for interior areas. Rapid drying: 15-25 minutes, dry on touch. The pigments are free from lead, cadmium and chromium.

Code	Color	Package	Pack.
306.2070.AR	Silver	400 ml	6 pcs.
306.2070.OM	Modern gold	400 ml	6 pcs.
306.2070.OA	Old gold	400 ml	6 pcs.
306.2071.CO	Chrome gold	400 ml	6 pcs.
306.2071.CA	Chrome silver	400 ml	6 pcs.



**PAINT FOR DOMESTIC APPLIANCES**

High quality and durability acrylic paint. Specific for domestic appliances, washing machines, refrigerators, dishwashers, microwave ovens, etc. High covering, non-yellowing, washable and scratch resistant after completely drying. The pigments are free from lead, cadmium and chromium.

Code	Color	Package	Pack.
306.2078	White	400 ml	6 pcs.



**MEDIUM TEMPERATURE PAINT + 120°C**

Is a paint made of modified silicone based resins, resisting heat up to 120°C. Non-yellowing, comes off, nor cracks. Dries quickly. Indicated for radiators, stove pipes, electric convectors, etc.

Code	Color	Package	Pack.
306.2080.MA	Brown	400 ml	6 pcs.
306.2080.CR	Cream	400 ml	6 pcs.
306.2080.AV	Ivory	400 ml	6 pcs.
306.2080.AL	Aluminium	400 ml	6 pcs.
306.2080.BI	White	400 ml	6 pcs.





### BLOT-COVER PAINT

Blot-cover acrylic paint. Formulated to cover different types of blot. Suitable for nicotine, soot, oil, tomato sauce, wine, vinegar, tea, coffee, lipstick, pastels, pencil, water and solvent based felt-tips. Usable as finishing product to renew and refresh panels and ceilings made of plasterboard. High covering, non-yellowing. Washable after 72 hours from the application with domestic detergents. Rapid drying: 15-20 minutes, dry on touch. The pigments are free from lead, cadmium and chromium.

Code	Color	Package	Pack.
306.2030	White Matt	400 ml	6 pcs.



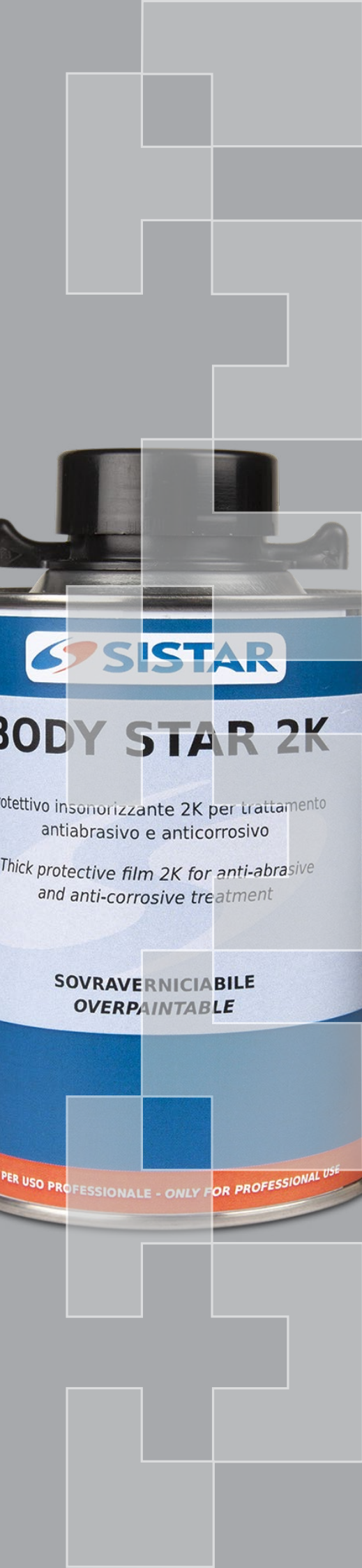

PAGE 71-76

CHEMICAL PRODUCTS



**U-SEAL 500**

1K Polyurethane adhesive sealant, fast, multi-functional and extremely versatile. Ideal for any need of sealing and elastic bonding in building industry, in windows market, in transport sector and industry. Suitable for building materials also porous, for acoustic and insulating panels, for frames of doors and windows made of wood and aluminium, metal and plastic components, glass, cement. Saus of 600 ml available on request.

Code	Color	Package	Pack.
304.0500.B	White	Aluminium cartridge 310 ml	12 pcs.
304.0500.GR	Grey	Aluminium cartridge 310 ml	12 pcs.
304.0500.N	Black	Aluminium cartridge 310 ml	12 pcs.
304.0521	Conical nozzle for cartridge		12 pcs.

**U-SEAL 501**

1K Polyurethane adhesive sealant with fast hardening, permanently elastic; can be brushed and smoothed after the application. Ideal for sealing and bonding of the substrates inside the body of car. Overpaintable after 45-60 minutes with the most important paints of Car-Refinish and Industry.

Code	Color	Package	Pack.
304.0501.B	White	Aluminium cartridge 310 ml	12 pcs.
304.0501.GR	Grey	Aluminium cartridge 310 ml	12 pcs.
304.0501.N	Black	Aluminium cartridge 310 ml	12 pcs.
304.0521	Conical nozzle for cartridge		12 pcs.

**U-SEAL 201 FAST**

1K elastic polyurethane structural adhesive. Ideal for bonding of windscreens and crystals of vehicles (< 35 kg). With fast hardening and high performance, has been specially developed to achieve safe and quick Drive Away Time in 2-4 hours on vehicles with airbags. Subjected to "crash test" in accordance with standard USA FMVSS 208/212 - TÜV Certified. On glass is necessary apply U-Primer 130.

Code	Color	Package	Pack.
304.0510	Black	Aluminium cartridge 310 ml	12 pcs.
304.0522.100	Truncated conical nozzle with V cut		100 pcs.

**SiMP® SEAL 60HV (no Primer)**

High Tack 1K structural adhesive, high modulus, permanently elastic with exceptional suction effect. With SiMP® Polymer Hybrid silane, without isocyanates and solvents. Ideal for bonding windshields without use of primer and ideal for structural bonding in the building sectors, transport, marine, metal construction and undergoing plastic to mechanical and thermal stress. Although not over-painted, it has excellent resistance to UV rays that make it ideal for applications subject to weather and sea water.

Code	Color	Package	Pack.
304.0504	Black	Cartridge PE 290 ml	12 pcs.
304.0522.100	Truncated conical nozzle with V cut		100 pcs.



**U-PRIMER 130**

Adhesion promoter specifically formulated for glass of vehicles. It makes a barrier against harmful UV rays, guarantees the complete protection of the under adhesive. Ideal for elastic structural adhesives such as U-Seal (in particular 201, 205 and 207) and SiMP-Seal. Ideal also for application on metal and plastic parts. Also great for spray applications.



Code	Color	Package	Pack.
304.0515	Black	Aluminium bottle 30 ml	25 pcs.

**APPLICATOR PAD**

Disposable applicator pad for Primer **U-PRIMER 130**.

Code	Pack.
304.0520.100	100 pcs.

**NOZZLES**

Spare nozzles for cartridge of sealents and 1K adhesives.

Code	Description	Pack.
304.0521.12	(A) Conical jet for cartridge	12 pcs.
304.0522.100	(B) Truncated conical jet with V cut for cartridge	100 pcs.
304.0523.100	(C) Conical jet for bag	100 pcs.
304.0524.100	(D) Truncated conical jet with V cut for bag	100 pcs.

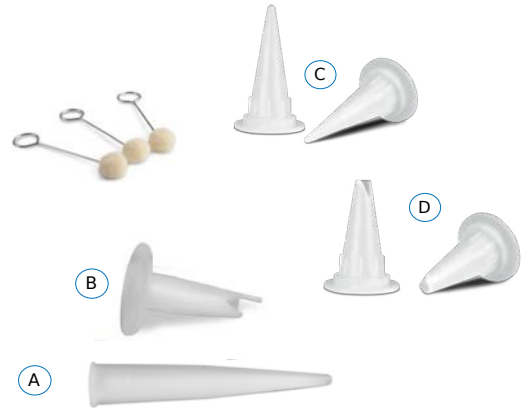

**1K BODY-STAR™**

Underbody protection, sound insulator, re-paintable, made of resins and gel. Anti-scratch and anti-corrosion. Application by sprayer and re-paintable after only 30-40 minutes.

Code	Color	Package	Pack.
304.0315.B	White	1,0 Kg	12 pcs.
304.0315.GR	Grey	1,0 Kg	12 pcs.
304.0315.N	Black	1,0 Kg	12 pcs.



**2K BODY-STAR™**

2K soundproofing protective with ultra high solid content, for anti-rust treatment, anti-corrosion and anti-abrasion of shells, wheel arches, side bands, interiors, spoilers, boot. Catalyze with specific hardener to 5% by weight and shake good. Application with spray with the special pneumatic gun screwing directly on the practical jar with a screw cap. Body Star 2K is overpainted with any type of finishing product.

Code	Color	Package	Pack.
304.0322.GC	Light grey	500 g + 25 ml Catalyst	10 pcs.
304.0322.N	Black	500 g + 25 ml Catalyst	10 pcs.
304.0322.B	White	500 g + 25 ml Catalyst	10 pcs.





### MULTI-STAR - Polyester Multifunctional Putty

2K Polyester Multifunctional Putty which combines the excellent filling capacity to the quality of surface finishing, smooth and without pores due to its composition very fine and homogeneous. Specific for supports in aluminium, galvanized, steel, polyester laminates and fiberglass GPR. You can apply in both thick and thin layers. Flexible.

Code	Color	Package	Pack.
321.1001.1	Yellow-Beige	1,800 Kg (with hardener)	10 pcs.
321.1001.02	Yellow-Beige	0,250 Kg (with hardener)	24 pcs.



### LIGHT-STAR - Universal Polyester Putty

2K Universal Polyester Putty with low specific weight containing micro-granules of glass that make it lighter 35% compared to traditional putty. Extremely easy to sand even after 2-3 days of application. Particularly suitable for large surfaces in market of cars, buses, trucks and commercial vehicles, but also in the nautical above the waterline.

Code	Color	Package	Pack.
321.1005.1	Yellow-Beige	1,0 Litro (with hardener)	10 pcs.



ALSO FOR  
CARBON FIBER

### PLASTIC-STAR Polyester Putty for Plastics & Carbon Fiber

2K Polyester special Putty for plastic and carbon fiber, very flexible, with excellent adhesion properties, specially formulated for repairing damage of bumpers, side skirts and plastic parts in general. Soft and easy to sand, does not clog the abrasive.

Code	Color	Package	Pack.
321.1010.02	Dark grey	0,250 Kg (with hardener)	24 pcs.



### ALU-STAR - Polyester Putty with Aluminium

2K Polyester fine Putty, very durable and flexible, containing aluminium pigments. Thanks to its properties of resistance to high temperatures and mechanical stress, is ideal for repair and reinforce damaged steel and aluminium surfaces. It is not necessary to use additional finishing putty.

Code	Color	Package	Pack.
321.1006.1	Light grey	1,800 Kg (with hardener)	10 pcs.

## FIBERGLASS REPAIR KIT

Kit for rapid repair of fiberglass, metal, plastic, car-body and industrial vehicles, boats, garden furniture and many other applications. Excellent adhesion to steel surfaces. Catalyze 2-3% maximum. Workable within 5-10 minutes at 20° C. Drying time: 20 minutes outside dust, 30 minutes on touch. Dry sandable with abrasive P80-P120.

Code	Color	Package	Pack.
321.1020.02	Transparent	Kit 0,250 Kg resin (with hardener) + 0,25 mq fiberglass	12 pcs.



## URKI PLAST

Flexible acrylic paint, specially formulated for painting of bumpers of vehicles and side bands. It has a satin textured look similar to the original. Pintable after 4 hours with acrylic paint with one or two layers.

Code	Color	Package	Pack.
314.0350	Black	1,0 L	6 pcs.
314.0352	Dark grey	1,0 L	6 pcs.



## URKI-PT

Renewing solvent based paint for synthetic materials and plastic parts. Used to treat bumpers, side bands, mirrors, masks, wings, internal trim, special rubber, synthetic tissue, vinyl roof, trunks of motorcycles, scooters and many other uses in different sectors. Pack. with sponge for applying the product. Does not make a film and does not stripping during the time.

Code	Color	Package	Pack.
314.0300	Black	Tube of 75 ml	1 pcs.
314.0302	Grey	Tube of 75 ml	1 pcs.



## CHROMALUX

Extra-mordant universal abrasive paste, specially formulated for car- body, nautic market and industry. Usable to remove sanding marks, to renew damaged surfaces and to remove the imperfections on many types of surfaces, such as new dried paint, hardened old paint, old and new gel coat. It is not water-soluble. Use only with polishing machine with speed variator, with hard and medium tampons or wool bonnet according with the surface.

Code	Color	Package	Pack.
340.0512.4	White	4,30 Kg / 2,5 L	4 pcs.





### NO-DUST LONG TIME

Concentrated dust collector to spray on the floor of the spray booths and adjacent areas. Keep on ground the particles of dust and overspray. Walkable after approx 5 minutes and remains active up to 5 days, depending on the dilution.

Code	Color	Package	Pack.
310.5105	Transparent	5 ,0 L	2 pcs.
310.5105.25	Transparent	25 ,L	1 pcs.
133.1500		Sprayer	1 pcs.



### TACKY PROTECTION

Sticky adhesive liquid to protect the walls of the spray booths in order to keep and retain the particles of dust and overspray. It is eliminated easy with water when it has finished its adhesive function. For a fast and easy replacement, apply it on masking film previously laid out to protect the walls of the cabin.

Code	Color	Package	Pack.
310.5110	Transparent	5,0 L	4 pcs.



### SKIN-UP S

Peelable solvent-based paint. The plastic and elastic film protects every surface and is easy to remove. Walkable after about 1 hour. Applicable by spray, roll or brush.

Code	Color	Package	Pack.
310.1001	White	5,0 L	2 pcs.



### AERCAP

Quick immersion cleaner for spray-guns and all equipment soiled with paint such as the balance, the lids of the mixing machine, etc. ... Not contains acids, does not ruin the chrome parts and does not damage the plastics. It can be used with its small washing basket 133.0090.

Code	Color	Package	Pack.
307.0010	Yellow	6,5 Kg	2 pcs.
307.0011	Yellow	30,0 Kg	1 pcs.
133.0090		Bucket and basket	1 pcs.



PAGE 77-92

EQUIPMENTS







### ORBITAL SANDER

Pneumatic orbital sander with mechanical suction of sanding dust. Orbit of 5.0 or 2.5 mm for fine grains. With speed controller. Use with pads Ø 150 mm with thread 5/16" with direct or ducted suction. The version with orbit of 5.0 mm is also usable as polishing machine to remove halos applying the soft polishing pad and microfiber bonnet.

#### Technical features

Speed	12.000 rev/min
Orbit	(A) 2,5 mm - (B) 5,0 mm
Pad (not included)	Ø 150 mm, Velcro connection,
Thread	5/16"
Air consumption	68,80 l/min (2.43 cfm)
Extent	(A) 216,2 mm - (B) 230,0 mm
Weight	(A) 934 g - (B) 900 g

Code	Description
<b>471.0836</b>	(A) 2,5 mm orbit
<b>471.0856</b>	(B) 5,0 mm orbit

### ORBITAL SANDER

Pneumatic orbital sander, very powerful (0.29 HP) and strong for an intensive use. Available with or without mechanical suction of sanding dust. Orbit of 5.0 mm. With speed controller. Use with pads Ø 150 mm with thread 5/16" without holes or with holes for direct or ducted suction. Weight: 890 g. It is also used as a polishing machine to remove the halos applying the soft polishing pad and microfiber bonnet.



#### Technical features

Speed	12.000 rev/min
Orbit	5,0 mm
Pad (included)	Ø 150 mm Velcro connection
Thread	5/16"
Power	0.22 kW (0.29 hp)
Air consumption	62 l/min (2.2 cfm)
Extent	(A) 150 mm - (B) 215 mm
Weight	(A) 890 g - (B) 960 g

Code	Description
<b>471.0870</b>	Without suction, pad without holes
<b>471.0872</b>	With suction, pad 6 Holes

### MINI ORBITAL SANDER

Pneumatic mini-orbital sander without suction of sanding dust. Orbit of 5.0 mm or 2.5 mm for fine grains. With speed controller. Use with mini-pads Ø 76 mm, thread 5/16".



#### Technical features

Speed	12.000 rev/min
Orbit	(A) 2,5 mm - (B) 5,0 mm
Pad (not included)	Ø 76 mm, Velcro connection
Thread	5/16"
Air consumption	62,3 l/min (2.2 cfm)
Extent	(A) 143 mm - (B) 195mm
Weight	(A) 610 g - (B) 720 g

Code	Description
<b>471.0840</b>	Orbit 2,5 mm without suction
<b>471.0842</b>	Orbit 5,0 mm with suction

**MINI ORBITAL SANDER - ANGULAR**

Pneumatic mini angular orbital sander without suction of sanding dust. Orbit of 1.5 mm. Use with micro-pads Ø 30 mm, thread M10, velcro or adhesive connection. With speed controller and digital display on the handle. Weight: 650 g.

**Technical features**

Speed	7.500 rev/min
Orbit	1,5 mm
Pad (included)	Ø 30 mm Thread M10, Velcro connection (Adhesive connection opcional Code 171.0315)
Power	0.22 kW (0.3 hp)
Air consumption	17 l/min (0.6 cfm)
Extent	187 mm
Weight	650 g

**Code****471.0860****ORBITAL POLISHING MACHINE - DOUBLE HANDLE**

Pneumatic orbital polishing machine, double handle, very powerful (0.35 HP) and strong. Orbit of 14.0 mm. Use with pads Ø 75 mm, thread 5/16". With speed controller and digital display on the handle.

**Technical features**

Speed	12.000 rev/min
Orbit	14 mm
Pad (included)	Ø 75 mm Thread 5/16", Velcro connection
Power	0.26 kW (0.35 hp)
Air consumption	62 l/min (2.2 cfm)
Extent	252 mm
Weight	1200 g

**Code****471.0865****ORBITAL SANDER AND POLISHING MACHINE - DOUBLE HANDLE**

Pneumatic orbital sander and polishing machine, double handle. Without suction. Orbit of 10 mm. With speed controller. Use with pads Ø 125 mm, thread 5/16".

**Technical features**

Speed	12.000 rev/min
Orbit	10,0 mm
Pad (not included)	Ø 124 mm Velcro connection
Thread	5/16"
Air consumption	90,7 l/min (3.2 cfm)
Extent	280 mm
Weight	1300 g

**Code****471.0830**



### ERASER

Pneumatic tool designed to eliminate any adhesive and signs without damaging painted surfaces or plastic parts. Use with rubber wheel code 176.0500. Thread 5/16". With speed controller, max. 2,600 rev/min.

#### Technical features

Speed	2.600 rev/min
Thread	5/16"-24
Power	0.37 kW (0.5 hp)
Air consumption	99 l/min (3.5 cfm)
Extent	225 mm
Weight	800 g

#### Code

**471.0875**

### PNEUSEAL 400 / 600

Pneumatic professional gun for extrusion of 1K sealants with medium viscosity in cartridge of 290/310 ml and sausage of 300 ml and 400 ml. With controller of air pressure and various accessories. Working pressure: 4-8 bar, max. 10 bar. Push power: 160 kgf (8 bar). Length of aluminium tube: 270 mm. Weight: 1.125 Kg. PNEUSEAL 600 for sausage of 600 ml is available on request.



Code	Description
<b>468.0115</b>	PNEUSEAL 400 for cartridge of 290/310 ml and sausage of 300/400 ml
<b>468.0116</b>	PNEUSEAL 600 for sausage of 300/400/600 ml

### PNEUSEAL 450

Pneumatic professional gun for extruding 1K sealants with medium viscosity in cartridges of 290/310 ml and bags of 300/400 ml. Thanks to the push-stage piston the product never comes in contact with the air. Complete of air pressure regulator and various accessories. Pressing work: 4-8 bar, max. 10 bar. Pushing force: 160 kgf (8 bar).



SUITABLE FOR  
ADHESIVE FOR  
GLASS

#### Code

**468.0113**

**SPRAYSEAL 300**

Pneumatic professional gun for spraying and extrusion of 1K sealants (MS-Polymer type spray-Simp) in standard plastic cartridge of 290/310 ml. Thanks to the included accessories, to the different possibility of adjustment of the product and to the pulverization of material, it's possible to get more or less "orange peel" surfaces. Working pressure: 3-5 bar, max. 8 bar. Air Consumption: 200-300 L/min.



Code

468.0130

**PNEUSEAL 300**

Pneumatic professional gun for extrusion of silicones and 1K sealants with medium viscosity in cartridge of 290/310 ml. Body of gun is made of brass, tube and rings is made of aluminium. Thanks to the self-discharging valve, the extrusion stops automatically when the control lever is released. Working pressure: 4-8 bar, max. 10 bar. Push power: 160 Kg (8 bar). Weight: 0,850 kg.



Code

468.0110

**MANUSEAL 400**

Manual professional gun made of metal with tube and rings made of aluminium; for extrusion of 1K sealants with high viscosity in cartridge of 290/310 ml and saus of 300 ml and 400 ml. Handle rubber coated for no-slide. Push power: 300 kgf. Push bar: hardened steel. Clutch: calibrated hardened steel. Weight: 1,010 kg.



Code

468.0156



**MANUSEAL 300**

Manual professional gun completely made of metal for extrusion of 1K sealants with medium-high viscosity in cartridge of 290/310 ml. Push power: 250 kgf. Push bar: hardened steel. Clutch: calibrated hardened steel.

Weight: 0,850 kg.

Code

468.0153

**MANUSEAL 290**

Manual gun made of metal for extrusion of 1K silicones and sealants with low viscosity in cartridge of 290/310 ml. Push power: 120 kgf. Push bar: hardened steel with hexagonal section. Weight: 0.520 Kg.

Code

468.0150

**ACCUSEAL 300/400/600**

Cordless professional gun with battery for extrusion of 1K sealants with medium-high viscosity in cartridges of 290/310 ml and sausage of 400 ml and 600 ml. Battery: Rechargeable made of Lithium-ion (Li-ion) 7.4 V - 1.3 A. Push power: 300 kgf. With system to prevent dripping of the product after work. With speed controller for better control of supply (Speed 6.9 mm/sec). Safety lever to prevent accidental activation of the gun. LED light on the handle to work in areas of poor lighting. Weight: 1,250 / 1,400 Kg. Plastic case with charger.



Code	Description
468.0120	ACCUSEAL 300 for cartridge of 290/310 ml
468.0123	ACCUSEAL 400 for cartridge of 290/310 ml and sausage of 400 ml - on request
468.0125	ACCUSEAL 600 and sausage of 600 ml - on request
468.0129	Replacement battery for accessories



## PNEUBODY 100

Professional pneumatic gun for application and spraying of underbody protective, anti-rust, soundproofing and waxes, both solvent-based that water-based. Thanks to the pressure of tank, the gun can use products with or without standard cans of 1 Kg/L. Working pressure: 2-4 bar, max. 8 bar. Air consumption: 200-300 L/min.

### KIT PNEUBODY 100

Kit with 3 extensions for underpressure pneumatic gun Pneubody 100. The Kit allows the application of soundproofing, body and protective waxes in areas hard to access.

Code	Description
468.0100	Gun Pneubody 100
468.0101	Kit extention 1500 mm x Ø 6 mm.

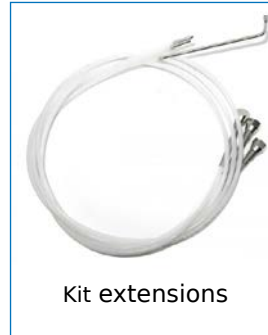

## PNEUBODY 90

Professional pneumatic gun with adjustable nozzle for application and spraying of underbody protective, anti-rust, soundproofing and waxes. It can connect directly to the can of 1 or 2 kg/L with special thread 42x3. Working pressure: 3-6 bar, max. 8 bar. Air consumption: 200-300 L/min.



Code	Description
468.0090	Pneubody 90 for cans of 1 l/kg e 2 l/kg
468.0090.05	Pneubody 90 for cans of 500 ml/g
468.0091	Extention for cans 500 mm x Ø 10 mm



## PNEUBODY 80

Professional pneumatic gun with adjustable nozzle for application of underbody protective, anti-rust, soundproofing and waxes. It can connect directly to the can of 1 or 2 kg/L with special thread 42x3. With extension for molded case.



Code
468.0080

**G-2005 HVLP**

Gravity spray gun with HVLP technology. Designed for quality painting in car-body shop with solvent-based or water-based paints. Head, nozzle and needle are made of stainless steel with extreme precision in order to obtain an excellent atomization. Available with nozzle Ø 1.4 mm for paint and clear coat and with nozzle Ø 1.8 mm for primer.

Code	Description
440.0020.14	Nozzle Ø 1,4 mm
440.0020.18	Nozzle Ø 1,8 mm
440.0021.Ø	Cap tip & needle kit with spare part Ø 1,4-1,8 mm
440.0021.600	Nylon cup 600 ml

**AEROGRAFO A GRAVITA'**

Gravity spray-gun designed for painting of all supports in a lot of sectors: industry, engineering, wood, carpentry, metal, building, industrial car-body shop. The body is made of nickel plated brass, the nozzle is made of brass and the needle is made of stainless steel. Nozzles: Ø 1,2-1,4-1,5-1,6-1,7-1,8-1,9-2,0-2,2-2,5-3,0 mm.

Code	Description
440.0050.Ø	Spray-gun with nylon cup
440.0052.Ø	Spray-gun with aluminium cup
440.0055.Ø	Cap tip & needle kit with spare part

**SUCTION SPRAY GUN**

Suction spray gun designed for painting of all supports in a lot of sectors: industry, engineering, wood, carpentry, metal, building, industrial car-body shop. The body is made of nickel plated brass, the nozzle is made of brass and the needle is made of stainless steel. With aluminium tank of 1 L with nylon cap and bayonet connection. Nozzles: Ø 1,2-1,4-1,5-1,6-1,7-1,8-1,9-2,0-2,2-2,5-3,0 mm.

Code	Description
440.0054.Ø	Suction spray-gun
440.0055.Ø	Cap tip & needle kit with spare part

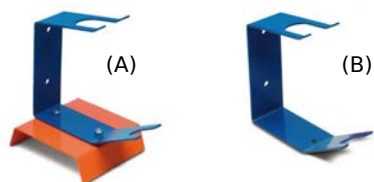
**SUPPORTS FOR SPRAY GUNS**

Suitable to put away the gravity spray guns after use or during the filling of the cup.

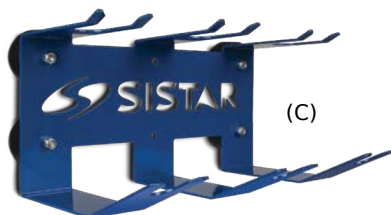

Codice	Description
440.5150	(A) Support with base plate
440.5151	(B) Support for wall
440.5152	(C) Magnetic support for 3 spray-gun

**PROFESSIONAL MINI SPRAY GUN**

Professional mini gravity spray gun with HVLP technology. Designed for quality touch-up and spot-repair in car-body shop with solvent-based and water-based paints. Nozzle and needle are made of stainless steel. Nozzles Ø 0,5 - 0,8 - 1,0 mm.

Codice	Description
440.0056.Ø	Mini gravity spray-gun with nozzle Ø 0,5 - 0,8 - 1,0 mm
440.0057.Ø	Proiettore completo di ricambio
440.0056	Nylon cup 125 ml

**MINI SPRAY GUN**

Mini gravity spray gun. Designed for small painting in car-body shop, design on glass, ceramics, etc. Nozzle and needle are made of stainless steel. Nozzles Ø 0,5 - 0,8 - 1,0 mm.

Codice	Description
440.0058.Ø	Mini gravity spray-gun with nozzle Ø 0,5 - 0,8 - 1,0 mm
440.0059.Ø	Proiettore completo di ricambio
440.0056	Nylon cup 125 ml

**DIGITAL PRESSURE GAUGE**

Strong and accurate digital pressure gauge for application to spray guns in order to have a clear reading of the air pressure. The side wheel allows a fast and easy adjustment.

- Connection: thread 1/4 "
- Pressure Range: from 0 to 17 bar
- Accuracy: ± 2%
- Working temperature: 0 to 45 ° C
- Battery: 3V DC
- Battery life: 1500 hours (continuous)
- Size: 44 x 30 x 36 mm
- Weight: 110 g

Code
440.0010

**DEVILBISS ANALOGICAL GAUGE**

Gauge to adjust and control the inlet air pressure to the spray gun. Back adjustment knob comfortable also for left-handers. Calibrated up to a pressure of 10 bar (145 psi). Universal 1/4 " BSP. Display Ø 35 mm. Weight 158 g.

**DEVILBISS**  
AUTOMOTIVE REFINISHING

Code
811.HAV-501-B



# JetClean



## Innovative spray gun washer for professional painters.

The first and only one spray gun washer that uses spray cans for washing spray guns with disposable cup instead of the tanks of diluent for solvent-based paints or detergent for water-based paints. The spray gun will be clean and dry in a record time of just 20 seconds, ready for the next high-quality work.

### The JetClean benefits:

- Cost of the washing guns 3-4 times more economic than traditional systems.
- Consumption control; 1 spray can of 500 ml washes about 30 guns.
- Cleaning speed; only 20 seconds to get a clean and completely dry gun.
- No waste of time; it is not necessary to dismantle cap, nozzle and needle of the gun.
- The gun is ready for the change of the color in a very short time.
- Minimum consumption of solvents and water based detergents for the cleaning.
- Lower purchase of solvents in order to not exceed the legal limit.
- Lower volume of products to be stocked.
- Lower weight to be transported compared to the solvent drum.
- Lower risk of fire.
- Waste products or solvents to be recycled reset.
- Elimination of odors and vapors during the washing of the gun.
- No more sketches and solvent splashes.
- Washing area more clean and orderly.
- Very compact machine; sizes only 245 x 275mm x 900 mm in height, 12 Kg maximum.
- Compact: if set up no on the wall doesn't takes up space on the ground or on bench work.
- Durable: totally made in stainless steel.
- Practical: also for left-handers.
- Simple: it works by connecting to the compressed air with pressure of 6-8 bar maximum.
- With full automatic pressure reducer to 2.5 bar for connection to the spray gun.



### SOLVENT SPRAY CAN FOR SOLVENT BASED PAINTS

Jumbo Spray 500 ml - Orange

Code

306.1013



### H2O SPRAY CAN FOR WATER BASED PAINTS

Jumbo Spray 500 ml - Blu

Code

306.1004



Code

480.1010

**RIWAX**  
beauty for cars

### ELECTRONIC POLISHING MACHINE - MAKITA

Sander-polisher with adjustable speed electronically from 600 to 3000 rev/minute. Soft start. Power: 1200 W. Voltage: 220 V. Thread: M14. Pad for tampon or wool bonnet-disc: Ø 180 mm max. Light and easy to handle, it's sold with its sanding pad Ø 150 mm.



Code

785.5509

### ELECTRONIC POLISHING MACHINE - RIWAX

Powerful polishing machine of 1300 W with electronic speed controller from 800 to 2400 rev/minute. Voltage: 220 V. Thread: M14. With accessories and spare parts in practice case.

**RIWAX**  
beauty for cars



Code

785.5511

### DUAL ACTION POLISHER RIWAX

Orbitl polisher of high power (880 W), Dual Action with orbit of 21 mm large diameter. The orbital polisher, compared to conventional rotary polishing machines, prevents the formation of holograms on polished surfaces, without the necessity to remove them with another polishing operation.

#### Technical features:

Voltage: 220-240V AC - 50 Hz

Variable speed: 1800-4800 OPM (orbits/minute)

Thread: 5/16 "

Weight: 2,500 kg ca

**RIWAX**  
beauty for cars



Codice

785.5713

### EXTRACTION MACHINE FOR WASH INTERIORS OF CARS

Wash-suction machine for thorough cleaning of the textile coatings and fabric upholstered seats. After spraying Cabin-Clean or Simply-Clean on the areas to be cleaned, use the machine that, injecting clean water, dissolves dirt contents into the tissue and automatically sucks. The fabrics are cleaned, perfumed and almost completely dry.

**RIWAX**  
beauty for cars



Code

785.6200





**RIWAX**  
beauty for cars



### BLUE BOX

Plastic box to contain the Riwx polishing products and have them in order and within reach. Robust and with lid. Fund watertight. Size: 290 x 390 x 300 mm.

Code
785.5613

**RIWAX**  
beauty for cars



### WASHER

Manual washing machine for microfibre cloths used for cleaning and polishing of surfaces. Compact, practical and economical. With two rubber rollers to squeeze the microfibre cloths. It made of strong plastic and has a handle for carrying.

Code
785.5515

### CASE FOR TOOLS

Multi-use case for hand tools, equipment, polishing bottles, pads, etc .. Very strong, it is made in polypropylene. With a mobile tray and two internal separators. Blue color. External size: 515 x 287 x H 338 mm.



### CASE FOR RIWAX POLISHING KIT

Polypropylene case with handle into the structure. Light blue. External size: 395 x 300 x H 103 mm.

Code	Color
910.2032	Blu
910.2035	Azzurro

### RIWAX EXHIBITOR

Elegant and practical Riwx exhibitor for professional products as PX, RX and RS Car Refinishing Nautic Line or the Do-It Yourself. Made of sturdy plastic, it has 4 fixed shelves. Easy to move thanks to the four swivel wheels. The exhibitor is delivered in free loan to the Dealers who buy Riwx line.



Code
785.4200

### EXHIBITOR FOR SISTAR SPRAY LINE

Exhibitor of new concept and elegant design. Made of white laminated wood, with 4 swivel wheels to move it easily. With 6 shelves to expose 42 different articles (3 shelves of 7x4 cm + 3 shelves of 7x5 cm). It can accommodate up to 189 spray cans. With 2 side pockets for brochures. Size: 540 x 360 x h 1800 mm. The exhibitor is delivered in free loan to the Dealers who buy Sistar Spray line.



Code
406.0100



### FILL-ONE MANUAL MACHINE

Manual filling machine to fill the pre-charged spray cans with special Fill-Cap. This machine has the same benefits of pneumatic version but it works without the need for compressed air. Practical, simple, chip, transportable, usable everywhere. Suitable for Customers who do not have the compressor and don't have a high request of spray cans with special colors.

Code
406.0038



### FILL-ONE PNEUMATIC MACHINE

Pneumatic filling machine to be connected to a compressor. It requires a pressure of 7-9 bar/130-100 psi. Completely automatic and safe, it is activated by closing the front door. It's complete of aluminium container for the cap of spray can. Very compact: only Ø 135 mm and 385 mm height. Can be fixed on the workbench or on metal base with the articles 406.0041. Can be fixed also to the wall with the support 406.0042; this solution is perfect for have the machine at handy without taking up space.

Code
406.0040



### WORK BENCH SUPPORT

Painted strong metal base to support the Fill-One pneumatic machine. With rubber feet and screw of 20 mm.



### WALL SUPPORT

Painted strong metal bracket to fix the Fill-One pneumatic machine to the wall. With screw of 20 mm.

Code	Description
406.0041	Work bench support
406.0042	Wall support



### AIR PRESSURE GAUGE

With support and quick connection for the tube of compressed air. Apply near the Fill-One pneumatic machine in a place clearly visible in order to have under control the pressure of 8 bar necessary for proper and safe working.

Code
406.0043

**NOISELESS DRY COMPRESSOR**

Noiseless dry compressor is the ideal for Fill-One machine. Powerful and without maintenance is designed specially for all environments where it is not possible put a noisy compressor. It's compact and takes up little space thanks to its vertical structure.

Tank: 24 liters

Engine Power: 1.5 HP / 1.1 kW

Maximum pressure: 10 bar

Voltage: 230V

Air: 138 L / min at 5 bar



Code
406.0048

**NOISELESS OIL COMPRESSOR**

Noiseless oil compressor - only 40 dB (A) - designed for Fill-One filling machine when it's located inside the store. It's compact and takes up little space.

Tank: 24 liters

Engine Power: 0.5 HP / 0,35 kW

Maximum pressure: 8 bar

Voltage: 230V

Air: 37 L / min



Code
406.0047

**PNEUMATIC FILLING MACHINE**

Necessary machine to fill the spray cans with traditional system. Pneumatic automatic version to be connected to the compressor.



Code
406.0053

**MANUAL FILLING MACHINE**

Necessary machine to fill the spray cans with traditional system. Manual hydraulic version. It does not require the compressor.



Code
406.0050



# Mr. Komodo™

EUROPEAN PATENT AND REGISTERED COMMUNITY DESIGNS

N° patent EP 10006485.6-2425/2266441

## WORKING ON YOUR KNEES IS NO LONGER A TOUGH WORK!

Mr. Komodo™ is the ideal solution for those who often work on their knees. Thanks to its innovative features Mr. Komodo™ will let you hold the most comfortable and correct position even for a long working time and it will help to prevent tiredness to your legs and back.

Mr. Komodo™ will definitely improve your position and also your health.

### Benefits of Mr. Komodo™

- Its unique shape allows to kneel very easy and to get up leveraging only on the legs, without straining the lower back for an advantage of the back.
- The seat and the pillows for knees are made of soft polyurethane foam covered with durable washable leather-like.
- The seat is adjustable in height, depth and inclination in order to adapt perfectly to every requirement. The tilting seat follows all movements supporting the back in every position.

- The three wheels guarantee a perfect adhesion on any type of floor even if not planar. Their position has been studied specifically to eliminate the risk of tipping.
- The version with the swivel front wheels guarantees the maximum agility during the shifts in every direction.
- The version with the fixed front wheels, wide and strong, guarantees stability and smoothness also on irregular surfaces and grids.
- It is easy to carry thanks to the comfortable handle and a content weight.
- The frame is made of steel 20/10, painted with powder also for outdoor use.
- Mr. Komodo™ has a space between the knees to hold working tools.

COMPLETELY DESIGNED  
AND MADE IN ITALY



**490.0105** Version with swivel front wheels.



**490.0100** Version with fixed front wheels.





 **SISTAR**

PAGE 93-98

**MEASURING AND  
CONTROL INSTRUMENTS**

[BACK TO  
INDEX](#)



#### BYKO-TEST MPOR

Dual thickness gauge for quick and easy measurement of thicknesses of coatings applied on ferromagnetic and non-magnetic substrates. Automatically identifies the substrate on which it is carrying out the measure and choose for themselves the appropriate test method. statistical functions: min., max., average, dev. Standard. Probe: Integrated with spring that ensures a constant pressure on the surface to be measured. Display: 2 illuminated LCD. Measuring range: up to 2000 my. Accuracy:  $\pm 1\%$  up to 50 my,  $\pm 2\%$  from 50 to 1000 my. Standard equipment: carrying case, 2 AA batteries, protective cap, calibration plates, instructions. Size: 64x30x85 mm. Weight 60 g.

#### Code

401.0033



#### BYKO-TEST 4200 and 4500

Thickness gauge for measuring thicknesses of coatings applied on ferromagnetic and non-magnetic substrates. Probe: integrated. Display: LCD. Measuring range: up to 3000 my for Fe; up to 3000 my for NFe. Accuracy:  $\pm 3\%$  up 1000 my. Standard equipment: carrying case, 2 AA batteries, calibration plates, calibration certificate, instructions. Size: 100x62x27 mm. Weight 130 g.

#### Code

401.0031

#### Description

Byko-Test 4200 - Only for Fe

401.0032

Byko-Test 4500 - Dual for Fe and Nfe



#### ELCOMETER 456 FNFB-S

Dual thickness gauge for the measurement of coatings applied on ferromagnetic and non-magnetic substrates. Non-destructive, electronic with digital display LCD. Probe: External wire (not included). Measuring range: up to 1500 my. Accuracy:  $\pm 1-3\%$  up to 1500 my. Standard equipment: 2 AAA batteries, instructions. Other probes available on request.

#### Code

401.0045

#### Description

Elcometer 456 FNFB-S (without probe)

401.0048

Dual probe FNF1 standard



#### ELCOMETER 415

Dual thickness gauge for the measurement of coatings applied on ferromagnetic and non-magnetic substrates. Non-destructive, Electronic with LCD display. Integrated probe. Measuring range: up to 1000 my. Accuracy:  $\pm 3\%$  or  $\pm 3$  my. Resolution 1 my. Standard equipment: 2 AAA batteries, instructions.

#### Code

401.0060



## BYKO-CUT UNIVERSAL

Universal instruments for:

- Measurement of thickness (2-2000 my) of coatings applied on each substrate by the destructive method.
- Adhesion test with the cross-cut test complies with ASTM D 3359 and DIN 53151
- Proof of hardness according to Bucholz in accordance with DIN EN ISO 2815
- Microscopic inspection for detecting defects on the surface: pores, cracks, bubbles, etc.

Standard equipment Byko-cut universal: swivel bracket with 3 blade thickness (N ° 1-13), incorporated microscope (scale 0-2 mm), LED, battery, instructions.

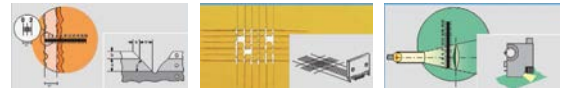

Code
401.0090

## WET COMB GAUGE

Reusable hexagonal thickness gauge made of steel stainless steel to control the thickness of the paint film still wet. Six measuring sides from 25 to 2000 my.



Code	External diameter
401.0155	90 mm

## CALIBRATION KIT

Calibration kit for thickness gauge with 2 calibration plates (ferromagnetic and non-magnetic) and 5 calibration sheets from 10, 50, 100, 350, 1000 my. Complete with certificate.



Code
401.0082

## CABIN LIGHT BYKO-SPECTRA

With 3 different light sources: daylight (D65), lamp Incandescent (A), fluorescent lamp (CWF). Ideal for general evaluation of small or large colour laboratory samples, in production and in the paint shop. The cabins lights offer the possibility of a comparison of standard and samples in neutral colour environment. Single Switch for each source bright. It can be assembled in few minutes without tools.

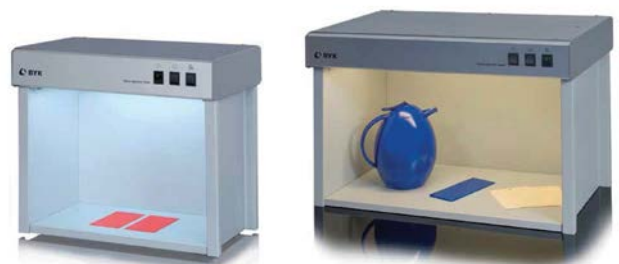

Code	Description	External size
403.0030	Mini	46x52x34 cm
403.0031	Basic	48x67x42 cm



**MICRO ANALYZER**

Magnifying glass with incorporated indirect light for visual control of sanding and painting defects. Magnification: 30X. Focus: micrometer. Power: 2 AA batteries LR6 1.5V batteries (not included).



Code
403.0050

**RHOPOINT**  
INSTRUMENTS

**GLOSSMETRO NOVO-GLOSS LITE RHOPOINT**

Optical-electronic portable instrument, with digital display, for the measurement of the gloss of dry paint products. Provided with three reading angles: 60° universal with medio gloss, 20° for high gloss, 85° for mat surfaces. Standard equipment: 4 AA batteries, calibration plate, carrying case.

Code	Reading angle	Size	Weight
403.0090	Mono-angular 60°	h.65x140x50 mm	390 g
403.0091	Bi-angular 20°-60°		530 g
403.0092	Tri-angular 20°-60°-85°		

**BYK** Gardner

**GLOSSMETRO BYK MICRO-GLOSS**

Optical-electronic portable instrument, with digital display, for the measurement of the gloss of the dry paint products. The intelligent self diagnostics alerts when to calibrate and control even if the standard is clean. It has a 10 year guarantee for the lamp life. Available with three reading angles: 60° universal with medium gloss, 20° for high gloss, 85° for mat surfaces. Standard equipment: 1.5V battery, calibration plate, certificate, software, PC cable, instructions, carrying case.

Code	Reading angle	Size	Weight
403.0093	Mono-angular 20°	h.73x155x48 mm	400 g
403.0094	Mono-angular 60°		
403.0095	Tri-angular 20°-60°-85°		

**elcometer**

**ELCOMETER 107 CROSS HATCH CUTTER**

The Elcometer 107 Cross Hatch Cutter for adhesion tests provides an instant assessment of the quality of the bond to the substrate. Due to its rugged construction this cross hatch gauge is ideal for thin, thick or tough coatings on all surfaces. An ideal field or laboratory test. DIN EN ISO 2409.

Codice	Description
403.0165	Cross Cutter with 6 blade 1 mm (< 60 µm)
403.0166	Cross Cutter with 6 blade 2 mm (60 ÷ 120 µm)
403.0167	Cross Cutter with 6 blade 3 mm (> 120 µm)
403.0171	Blade spare part 1 mm
403.0172	Blade spare part 2 mm
403.0173	Blade spare part 3 mm



## VISCOSITY CUPS

Suitable to determining the viscosity of paint products according to the time of deflow.

**FORD n° 4:** Guaranteed within 2% of application recommended range. Suitable for liquids with low viscosity. Body made in aluminum, stainless steel nozzle, calibration with standard oils. Complete with certificate (ASTM D 333, D 365, D 1200).

**DIN 4 mm:** Suitable for liquids with low viscosity. Body made in anodized aluminum, polished interior and fixed nozzle made in stainless steel, with standard calibration oils. Complete with certificate (DIN 53211).

**ISO 4 mm:** Due to its extended measuring range, this cap is the ideal complement to the DIN cup. Body made in anodized aluminium, polished interior and fixed nozzle made in stainless steel. Calibration with standard oils. Complete with certificate (DIN EN ISO 2431 - ASTM D 5125).



Code	Description	
404.0244	(A)	FORD n° 4
404.0246	(B)	DIN 4 mm
404.0248	(C)	ISO 4 mm
404.0239	(D)	Support adjustable in height

## IMMERSION VISCOSITY CUPS

They determine the viscosity of paint products according to the time of deflow, taking them directly from the container or from the place of production. With handle made in steel. Available in plastic with brass nozzle Ø 4 mm (DIN 53211) and aluminum with stainless steel nozzle Ø 4 mm (DIN EN ISO 2431). ISO 2431 - ASTM D 5125).



Code	Description
404.0231	Plastic cup DIN 53211
404.0232	Aluminium cup ISO 2431

## TESTO 830-T1

Manual infrared thermometer with laser pointer. Ideal for quick and accurate measurement without contact of temperature of surfaces. Standard lens with 10:1 ratio (at 50 cm it measures the temperature of the surface of 5 cm in diameter). Optical and acoustic alarm over set limits. Measuring range: from -30° C to + 400° C. 9V battery.



Code	Size	Weight
405.8301	190x75x38 mm	200 g





**TESTO 625**

Portable electronic thermo-hygrometer, with integrated probe for measurement of the humidity and air temperature. The large display shows the min/max values and the dew point. For measures in difficult points, the terminal of hygrometric probe can be easily removed and attached to the handle through the cable-probe (accessory). Measuring range of probe: from 0% to + 100% RH., from -10 ° C to + 60 ° C. 9V battery.

Code	Size	Weight
405.0625	182x64x40 mm	195 g
405.9725	Prolunga cavo per probe igrometrica	

**TESTO 925**

Portable electronic thermometer, connected to thermocouple probes rapid and reliable (optional, not included). Continuous display of max/min values. Measuring range: from -60 ° C to + 1000 ° C (depending on the probe). Size: 182x64x40 mm. Weight: 171 g. 9V battery.

Code	Description	Measurement range
405.0925	Testo 925	
405.0792	① Sonda per aria	da -60°C a +400°C
405.0292	② Sonda a immersione/penetrazione	da -60°C a +400°C
405.0392	③ Sonda a contatto	da -60°C a +300°C

**TESTO 425**

Portable electronic thermo- anemometer, with telescopic probe for measurement of the speed and air temperature. The flow rate is displayed on the display. The min/max values are shown on the display. The Measuring range: 0 to 20 m / sec., -20 ° C to + 70 ° C. 9V battery.

Code	Size	Weight
405.0425	182x64x40 mm	285 g

**TESTO 680**

Electronic thermo-hygrometer for continuous measurement of humidity, temperature, dew point and max/min values. The mod. Testo 608-H2 has an accuracy of  $\pm 2\%$  RH and LED alarm to exceeding the set limit values. 9V battery. Measuring range: mod. 608-H1, from + 10% to + 95% RH., From 0 ° C to + 50 ° C. mod. 608-H2, from + 2% to + 98% RH., From -10 ° C to + 70 ° C.

Code	Description	Size	Weight
405.6081	608-H1	120x89x40 mm	168 g
405.6082	608-H2		



 **SISTAR**

PAGE 99-124

**PERSONAL** PROTECTION

[BACK TO  
INDEX](#)



<b>DUST</b>	Particles of variable size, generated by crushing of solid materials.
<b>MIST</b>	Particles of evaporated or mechanically nebulized liquids.
<b>FUMES</b>	Disrupted particles of solids by heating or combustion, with dimensions less than 4 microns.

LEVEL OF PROTECTION	
Class	Maximum concentration
<b>FFP1</b>	<b>Up to 4 x TLV</b>
<b>FFP2</b>	<b>Up to 12 x TLV</b>
<b>FFP3</b>	<b>Up to 50 x TLV</b>

**TLV = Limit value.** Weighted average concentration of a substance to which the operator may be exposed without adverse effects for the health.

**NR** = Disposable.

**D** = The filter passed the test about stoppage with Dolomite powder. Breathing resistance lower, longer, life.

**OV** = Organic vapour.



### SISTAR F1

FFP1 NR D  
EN149:2001+A1:2009.

Protection against solid and liquid harmful particles up to 4xTLV. Suitable for processing of ferrous metals, untreated wood, for the building, for the protection from aerosols without toxic substances.

Code	Package	Pack.
<b>501.2050</b>	20 pcs.	12 cf.



### SISTAR F1V

FFP1 NR D  
EN149:2001+A1:2009, with exhalation valve.

Protection against solid and liquid harmful particles up to 4xTLV. Suitable for processing of ferrous metals, untreated wood, for the building, for the protection from aerosols without toxic substances.

Code	Package	Pack.
<b>501.2051</b>	15 pcs.	12 cf.

## SISTAR F2V

FFP2 NR D  
 EN149:2001+A1:2009, with exhalation valve.  
 Protection against solid and liquid toxic particles up to 12xTLV.  
 Suitable for sanding in car-body shop and nautic market, for welding, for the protection from toxic dust and aerosols.



Code	Package	Pack.
501.2053	15 pcs.	12 cf.

## SISTAR F2CV - ACTIVATED CARBON

FFP2 OV NR D  
 EN149:2001+A1:2009, with exhalation valve and activated carbon.  
 Protection against solid and liquid toxic particles up to 12xTLV.  
 Suitable for sanding in car-body shop and nautic market, for painting and use of solvents with no dangerous fumes (less than TLV), for the protection from toxic dust and aerosols.



Code	Package	Pack.
501.2054	10 pcs.	12 cf.

## SISTAR F3V

FFP3 NR D  
 EN149:2001+A1:2009, with exhalation valve.  
 Protection against solid and liquid highly toxic particles up to 50xTLV. Suitable for dust and aerosols with high-toxicity such as chromium, nickel, lead, some pesticides and chemical liquid substances. Suitable for removal of amiantus.



Code	Package	Pack.
501.2055	10 pcs.	12 cf.



### JACKSON SAFETY FFP1

FFP1 NR  
EN149:2001+A1:2009.

Protection against solid and liquid harmful particles up to 4xTLV. Suitable for the processing of ferrous metals, untreated wood, for the building, for the protection from aerosols without toxic substances.

Code	Description	Package	Pack.
501.64250	Without exhalation valve	20 pcs.	8 cf.
501.64260	Double exhalation valve	10 pcs.	8 cf.



### JACKSON SAFETY FFP2

FFP2 NR  
EN149:2001+A1:2009.

Protection against solid and liquid toxic particles up to 10xTLV. Suitable for sanding in car-body shop and nautic market, for the welding, for the protection from toxic dust and aerosols.

Code	Description	Package	Pack.
501.64540	Without exhalation valve	20 pcs.	8 cf.
501.64550	Double exhalation valve	10 pcs.	8 cf.



### JACKSON SAFETY FFP2 - ACTIVATED CARBON

FFP2 OV  
NR EN149:2001+A1:2009, with activated carbon.

Protection against solid and liquid toxic particles up to 10xTLV. Suitable for sanding in car-body shop and nautic market, for the welding, for painting and use of solvents with no dangerous fumes (less than TLV), for the protection from toxic dust and aerosols.

Code	Description	Package	Pack.
501.64560	Double exhalation valve	10 pcs.	8 cf.



### JACKSON SAFETY FFP3

FFP3 NR D  
EN149:2001+A1:2009.

Protection against solid and liquid highly toxic particles up to 30xTLV. Suitable for dust and aerosols of high-toxicity such as chromium, nickel, lead, some pesticides and chemical liquid substances. Suitable for removal of amiantus.

Code	Description	Package	Pack.
501.64590	Double exhalation valve	10 pcs.	8 cf.



## JACKSON SAFETY FFP1



FFP1  
RD EN149:2001+A1:2009.  
**Folded, singularly packed.**

Protection against solid and liquid harmful particles up to 4xTLV. Suitable for the processing of ferrous metals, untreated wood, for the building, for the protection from aerosols without toxic substances.



Code	Description	Package	Pack.
502.62920	Without exhalation valve	20 pcs.	10 cf.

## JACKSON SAFETY FFP2



FFP2 RD  
EN149:2001+A1:2009.  
**Folded, singularly packed.**

Protection against solid and liquid toxic particles up to 10xTLV. Suitable for sanding in car-body shop and nautic market, for the welding, for the protection from toxic dust and aerosols.



Code	Description	Package	Pack.
502.62960	With exhalation valve	15 pcs.	10 cf.

## JACKSON SAFETY FFP2 - ACTIVATED CARBON



FFP2 OV NR  
EN149:2001+A1:2009, with activated carbon.  
**Folded, singularly packed.**

Protection against solid and liquid toxic particles up to 10xTLV. Suitable for sanding in car-body shop and nautic market, for the welding, for painting and use of solvents with no dangerous fumes (less than TLV), for the protection from toxic dust and aerosols.



Code	Description	Package	Pack.
502.62970	With exhalation valve	15 pcs.	10 cf.

**ELIPSE****A1P3. Without maintenance**

UNI EN405



Protection against organic gases and vapors up to 10xTLV. Protection against solid and liquid highly toxic particles up to 30xTLV. Suitable for painting in all applications (spray gun, powder), for exposure to fumes of solvents and most of the hydrocarbons, for dusts and aerosol with high toxicity such as chromium, nickel, lead, some pesticides and chemical liquid substances. Packaged in resealable pouch.

Code	Package	Pack.
503.0359.L	1 pcs.	10 masks

**Honeywell****FREEDOM™****Without maintenance**

UNI EN405

**NEW  
A2-P2**

Protection against gases and vapors up to 10xTLV. Protection against solid and liquid particles from 4 to 30xTLV. Suitable for painting and all other applications, depending on the model and supplied filters.

Code	Description	Package
503.0518	A1	1 pcs.
503.0519	A1-P1	1 pcs.
503.0520	A2-P2	1 pcs.
503.0534	A1+ Pre-filter C10	1 pcs.
506.0515	Pre-filter P1	20 pcs.
506.0516	Pre-filter P2	20 pcs.
506.0533	Pre-filter block	2 pcs.
Other categories of protection on request		

**ELIPSE SPR503****A1P3. With interchangeable filters**

UNI EN140



Half mask for protection from gases and organic vapors, dusts, metal fumes, mists, microorganisms like bacteria and viruses. Multi-purpose protection for substances in concentrations up to 1,000 ppm and from dusts and mists up to 50 TLV. Compact design, light and flexible which allows it to adapt perfectly to face and have a wide view, without interfering with the devices of eyes and ears protection. Large non-return central valve, allows to minimize the breathing resistance of the user and moisture inside the mask.

Code	Description	Package	Pack.
504.0338.L	Elipse SPR503	1 pcs.	10 masks
506.0341	Filters A1-P3	2 pcs. (1 couple)	6 couples

**Honeywell**

## VALUAIR PLUS

**For interchangeable bayonet filters**

UNI EN140

Half mask made of soft synthetic rubber, silicone-free. Adjustable harness with four points and belt. Suitable for painting and all other applications, depending on supplied filters.



Code	Size	Package
504.0501.M	Medium	1 pcs.
504.0501.L	Large	1 pcs.

## MX/PF F 950

**With interchangeable bayonet filters**

UNI EN 140 CE

Half mask with double lateral connection for Interchangeable bayonet filters. Facial ergonomic and enveloping soft silicone rubber with triple seal gasket flange. Particularly suitable for long use or harsh working conditions. 4 harness attachment points with adjustable elastics. Possible to wear goggles or visors of protection.



**Honeywell**

Code	Package
504.6801	1 mask

## BAYONET FILTERS

**For Valuair Plus and Optifit Twin**

UNI EN14387 - UNI EN143

With bayonet connection of Honeywell Protection.

**Honeywell**

Code	Description	Package
506.0548	A1	10 pcs.
506.0504	A2	5x2 = 10 pcs.
506.0509	P3	5x2 = 10 pcs.
506.0510	A2P3	3x2 = 6 pcs.
506.0515	Pre-filter P1	20 pcs.
506.0516	Pre-filter P2	20 pcs.
506.0517	Pre-filter block	2 pcs.
Other categories of protection on request		



Honeywell®

**OPTIFIT TWIN L**

**For interchangeable bayonet filters**  
UNI EN136

Full-face mask made of silicone rubber, with panoramic polycarbonate screen anti-scratch and anti-fog. Adjustable harness with five points. Suitable for painting and all other applications, depending on supplied filters.

Code	Description
505.5251.L	Optifit Twin L
505.0174	Protective films 25 pcs.

Honeywell®

**AIRVISOR 2**  
**Kit for paint**

UNI EN14594:2005

Respirator powered by compressed air. The device includes a helmet with acetate shield, a filter for belt made of activated carbon with flow control and acoustic alarm for low pressure. Use in presence of gas, vapors, mists, dusts and fumes up to 1000xTLV - FPN: 200. Working pressure: 7 bar. Nominal air flow: 260 l/ min.

Code	Description	Package
507.0021	Airvisor 2 - Kit	1 pcs.
507.0071	Kit visor - spare part	1 pcs.
507.1404	Filter with activated carbon - spare part	1 pcs.
507.1408	Tyvek cover neck - spare part	5 pcs.
507.1503	Polycarbonate screen - spare part	1 pcs.
507.1504	Acetate shield - spare part	1 pcs.
507.1507	Protective films	10 pcs.
507.1510	Other spare parts on request	5 pcs.

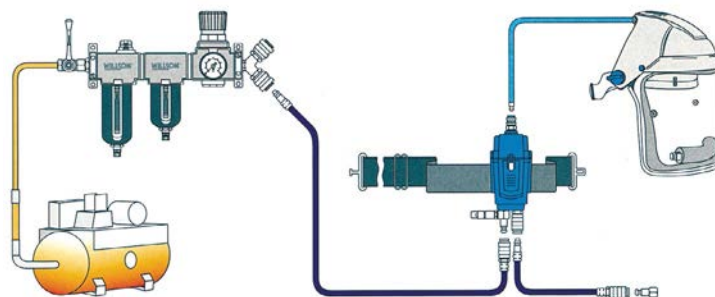
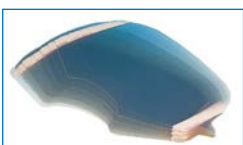



**Honeywell**

**V-MAXX**

EN 166

**Compatible with use of masks.**

Glasses with colorless lens made of polycarbonate, anti-scratch for mechanical protection or with colorless lens made of acetate, solvents resistant. High protection from the projection of particles, chippings, dripping and splashing of chemical substances.

Code	Description
512.5033	Polycarbonate
512.5034	Acetate
512.5038	Protective films in pack of 10 pcs



**JACKSON V50 CALICO**

EN 166

**Elastic band and interchangeable dipsticks.**

Glasses with two lenses made of polycarbonate, anti-scratch and colorless. Soft rubber sheath inside of the frame. High protection from the direct projection of particles and chippings.

Code
511.25672



**MILLENNIA**

EN 166

Sporting glasses made of polycarbonate with colorless and anti-scratch lens. With strings to support the neck. Protects against direct projection of particles and chippings.

Code
511.1031



**Honeywell**

**JACKSON V30 NEMESIS**

EN 166

Sporting glasses made of polycarbonate with colorless and anti-scratch lens. Dipsticks with soft and ergonomic tip. With strings to support the neck. Protects against direct projection of particles and chippings.

Code
511.25679



**Kimberly-Clark  
PROFESSIONAL**







### OVERFITTING GLASSES

EN 166

#### Overfitting on comparable eyeglasses.

Anti-scratch panoramic glasses made of polycarbonate. Protects against direct projection of particles and chippings.

Code

511.1050

**Honeywell**



### PERCAP

SNR 24 dB (H=27 - M=20 - L=18)  
EN352-2

Foldable headband with earplugs made of soft polyurethane foam.

Code

522.5720

Description

Total headband

522.5730

Earplugs refill

**Honeywell**



### LEIGHTNING L1

SNR 30 dB (H=31 - M=28 - L=23)  
EN352-1

Light and comfortable earmuffs with padded support. Adjustable cups.

Code

523.2422



### EAR PLUGS

SNR 34 dB (H=32 - M=28 - L=25)  
EN352-2

Disposable earplugs made of soft polyurethane foam. Package from 200 pcs.

Code

521.67210

## LE NORME EUROPEE - I PITTOGRAMMI



RISCHI MECCANICI  
EN 388

LIVELLO DI PRESTAZIONE\*

0al4 0al5 0al4 0al4

- └─ Resistenza alla perforazione
- └─ Resistenza allo strappo
- └─ Resistenza al taglio
- └─ Resistenza all'abrasione



Idoneità contatto con alimenti



MICRO-ORGANISMI  
EN 374 - 2



PROTEZIONE CHIMICA  
GENERALE  
EN 374 - 2



PROTEZIONE CHIMICA SPECIFICA  
EN 374 - 3



CONTAMINAZIONE  
RADIOATTIVA  
EN 421



RISCHI DA FREDDO  
EN 511

Codice lettera    Prodotto chimico

**A**    Metanolo

**B**    Acetone

**C**    Acetonitrile

**D**    Diclorometano

**E**    Disolfuro di carbonio

**F**    Toluene

**G**    Dietilamina

**H**    Tetraidrofurano

**I**    Acetato d'etile

**J**    n-eptano

**K**    Soda caustica 40 %

**L**    Acido solforico 96 %

LIVELLO DI PRESTAZIONE\*

0al4 0al4 0o 1

- └─ Permeabilità all'acqua
- └─ Resistenza al freddo da contatto
- └─ Resistenza al freddo convettivo



CALORE E FUOCO  
EN 407

LIVELLO DI PRESTAZIONE\*

0al4 0al4 0al4 0al4 0al4 0al4

- └─ Resistenza a grosse proiezioni di metallo fuso
- └─ Resistenza a piccole proiezioni di metallo fuso
- └─ Resistenza al calore radiante
- └─ Resistenza al calore da contatto
- └─ Comportamento al fuoco

\* Livello X : il test non è applicabile o il guanto non è stato testato.

### PROTECTION BLUE "HI RISK"

EN420, EN374-2, EN374-3, DPI Cat. III.  
Disposable gloves made of blue latex, very thick, powder free.  
Excellent mechanical resistance. Micro-ruvid finish to increase the grip. Extent 30 cm.



Code	Size	Package	Pack.
551.2970	M-L-XL	50 pcs.	10 cf.

### BLACK PLUS

EN420, EN455-1/2&3 - DPI Cat. I  
Disposable gloves made of black latex, medium thickness,  
powder free. Excellent mechanical resistance, suitable for  
contact with thinners. Micro-ruvid finish to increase the grip.  
Extent 24 cm.



Code	Size	Package	Pack.
551.2755	M-L-XL	100 pcs.	10 cf.

**STARGLOVES GREEN**

EN420, EN455-1/2&3, DPI Cat. I.

Disposable gloves made of green latex, finely powdered. Extremely soft and comfortable. Micro-ruvid finish to increase the grip. Extent: 24 cm.



Code	Size	Package	Pack.
551.2965	M-L-XL	100 pcs.	10 cf.

**STRARGLOVES WHITE**

EN420, EN374-2, EN374-3, DPI Cat. III.

Disposable gloves made of white latex, finely powdered. Extremely soft and comfortable. Micro-ruvid finish to increase the grip. Extent: 24 cm.



Code	Size	Package	Pack.
551.2960	M-L-XL	100 pcs.	10 cf.

**NITRIL TOP**

EN420, DPI Cat. I.

Disposable gloves made of light-blue nitrile, powder and latex free. Good mechanical resistance, suitable for contact with thinners and chemical substances. Micro-ruvid finish to increase the grip. Extent 24 cm.



Code	Size	Package	Pack.
553.2751	M-L-XL	100 pcs.	10 cf.

## STARLIGHT 100

EN420, EN388, DPI Cat. II.  
Light glove made of nylon mesh, coated with polyurethane, black colour. High dexterity. Suitable for maintenance work, also for precision works. Singularly packed in blister. Excellent mix between quality and price.



Code	Size	Package	Pack.
556.0100	M-L-XL	1 paio in busta Transparent	12 pair

## STARWORK 150

EN420, EN388, DPI Cat. II.  
Light glove made of nylon mesh, coated with nitrile, gray/white colour. Good abrasion resistance and dexterity. Suitable for maintenance work also heavy. Suitable for contact with wet surfaces with oil or solvents. Singularly packed in blister. Excellent mix between quality and price.



Code	Size	Package	Pack.
556.0150	M-L-XL	1 paio in busta Transparent	12 pair

## ULTRANE 548

EN420, EN388, DPI Cat. II.  
Light glove made of knitted nylon, coated with polyurethane, black color. High skill. Suitable for maintenance and precision works.



Code	Size	Package	Pack.
556.0548	8-9-10	12 pair	96 pair

## ULTRANE 551

EN420, EN388, DPI Cat. II.  
Light glove made of knitted nylon, coated with polyurethane, grey color. Excellent resistance to abrasion, high skill. Suitable for maintenance and accuracy works.



Code	Size	Package	Pack.
556.0551	8-9-10	10 pair	100 pair

**MAPA**  
PROFESSIONNEL



### ULTRANE 553

EN388 (4121), PPE Cat.II.

Light glove made of knitted nylon, coated with nitrile, grey/black color. Excellent resistance to abrasion, good skill. Suitable for heavy maintenance work, indicated for the contact with surfaces impregnated with oil or solvents.



Code	Size	Package	Pack.
556.0553	8-9-10	10 pair	100 pair

**MAPA**  
PROFESSIONNEL



### KRYTECH 579

EN420, EN388, DPI Cat. II.

Light glove anti-cut. Made of knitted polyethylene with high density, coated with polyurethane foam, white/grey color. Suitable for handling of metal sheets, crystals and objects that cause cuts. Excellent grip.



Code	Size	Package	Pack.
556.0579	8-9-10	12 pair	96 pair

**MAPA**  
PROFESSIONNEL

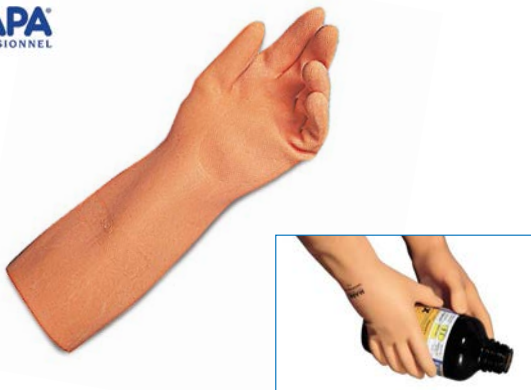

### INDUSTRIAL 299

EN420, EN388, EN374-2, EN374-3, DPI Cat.III.

Light waterproof glove with high thickness made of orange latex, not supported, interior flocked cotton, micro-ruvid handbreadth. Suitable for light mechanical works, also with chemical products. Thickness: 0.90 mm. Length: 31 cm.



Code	Size	Package	Pack.
555.0299	8-9-10	5 pair	50 pair

**MAPA**  
PROFESSIONNEL



### JERSETTE 301

EN420, EN388, EN374-2, EN374-3, EN407, DPI Cat.II.

Waterproof glove with extra thickness made of light-blue latex, with cotton support and micro-ruvid surface. Suitable for mechanical works with chemical products, temperature resistant up to 100°C. Thickness: 1.15 mm. Length: 31 cm.



Code	Size	Package	Pack.
555.0301	8-9	5 pair	50 pair



## TECHNI-MIX 415

EN420, EN388, EN374-3, EN 421, DPI Cat.III.  
 Light glove made of latex and neoprene, black color, not supported, internal flocked cotton, micro-ruvid handbreadth. Protection from chemical products, suitable for light handling works. Thickness: 0.60 mm. Length: 32 cm.



Code	Size	Package	Pack.
555.0415	8-9-10	10 pair	100 pair



## DUO-MIX 405

EN420, EN388, EN374-1, EN374-2, EN421, DPI Cat.III.  
 Glove made of latex and neoprene, yellow/blue color, not supported, interior flocked cotton, micro-ruvid handbreadth. Protection from chemical products, suitable for light handling works. Thickness: 0.70 mm. Length: 33 cm.



Code	Size	Package	Pack.
555.0405	8-9-10	10 pair	100 pair



## TECHNIC 401

EN420, EN388, EN374-2, EN374-3, DPI Cat.III.  
 Light glove with finishing made of neoprene, black color, not supported, interior flocked cotton, micro-ruvid handbreadth. Excellent protection from chemical products, suitable for light handling works. Thickness: 0.55 mm. Length: 31 cm.



Code	Size	Package	Pack.
555.0401	8-9-10	10 pair	100 pair



## ULTRANITRIL PLUS 492

EN420, EN388, EN374-2, EN374-3, DPI Cat.III.  
 Light glove made of nitrile, aquamarine color, internal flocked cotton, micro-ruvid handbreadth. Particularly suitable for the contact with solvents and paints. Excellent resistance to abrasion, high skill. Thickness: 0.38 mm. Length: 32 cm.



Code	Size	Package	Pack.
555.0492	8-9-10	10 pair	100 pair





**The collection** of Sparco Teamwork shoes is born from the idea of offering to the end-user a product with racing, light, comfortable and safe design. The new collection Sparco Teamwork is designed thanks to experience of Sparco about the search of maximum protection of the professional driver's foot. Shoes of high quality, made in the complete respect of the law.

**The uppers** are made with smooth grain leather, suede and nubuck. The use of natural leathers guarantees an high transpiration, optimum temperature and internal ventilation.

**The soles** are designed to have an high anti-slip coefficient. The unique design of tread, developed thanks to the result of specific researchs, has allowed to obtain some performances exceeding of 30% than required by the rules.

**sparco**  
-TEAMWORK-



### SPORT L OCCUPATIONAL

The shoes occupational are professional shoes, ultra-light, **without antisquashing toe**, certified for all works without the risk of fall from the top of blunt objects and where isn't the risk of handling of loads.

EN ISO 20347 O1

Low shoes made of suede, comfortable and light, suitable for all uses.

- Anti-perforation midsole made of aramid fiber
- Composite toe: **not this**

Code	Color	Size
540.7510BL	Blu	39/46

**sparco**  
-TEAMWORK-



### SPORT L - S1P

EN ISO 20345 S1P

Low shoes made of suede, comfortable and light, suitable for all uses.

- Anti-perforation midsole made of aramid fiber
- Composite toe



Code	Color	Size
540.7501RS	Red	39/46
540.7501NR	Black	39/46



## SPORT L - S3

EN ISO 20345 S3

Low shoes with uppers made of grain leather. Extremely comfortable and durable.

- Anti-perforation midsole made of aramid fiber
- Composite toe



Code	Color	Size
540.7506NR	Black	39/46

## SPORT H - S3

EN ISO 20345 S3

High shoes with uppers made of grain leather. Extremely comfortable and durable.

- Anti-perforation midsole made of aramid fiber
- Composite toe



Code	Color	Size
540.7503NR	Black	39/46

## RACING H - S3

EN ISO 20345 S3

Racing shoes, made of suede or nubuck. Reflective inserts for added security. Velcro strap for wrap the ankle.

- Anti-perforation midsole made of aramid fiber
- Composite toe



Code	Color	Size
540.7502NR	Black	39/46
540.7502OC	Ocra	39/46
540.7502AZ	Blu	39/46



**CURTISS - S1**

EN ISO 20345 S1

Low shoes made of perforated suede, lined with transpirant WingTex fabric. Ergonomic insole, outsole made of bi-density polyurethane. Composite toe.

Code	Size
541.0155	40/44 - Altre Size a richiesta

**FEELING - S1P  
JOGGER - S1P**

EN ISO 20345 S1P

High shoes, made of suede with inserts in Cordura, lined with transpirant WingTex fabric. Ergonomic insole, outsole made of bi-density polyurethane. Anti-perforation midsole made of steel, composite toe.

Code	Modello	Size
541.0211	Feeling S1P	40/44 - Altre Size a richiesta
541.0212	Jogger S1P	40/44 - Altre Size a richiesta

**SOYUZ - S1P**

EN ISO 20345 S1P

Open shoes made of perforated suede, lined with transpirant WingTex fabric, velcro connection. Ergonomic insole, outsole made of bi-density polyurethane. Anti-perforation midsole made of steel, composite toe.

Code	Size
541.0235	40/44 - Altre Size a richiesta

**REFLEX - S1P**

EN ISO 20345 S1P

Low shoes, made of perforated suede, lined with transpirant WingTex fabric. Ergonomic insole, outsole made of bi-density polyurethane. Anti-perforation midsole made of aramid fiber, composite toe.

Code	Size
541.0215	40/44 - Altre Size a richiesta



## TECNO-YARN™ Antistatic

DPI Categoria I.

Antistatic and transpirant overall. Made of Polyester Nega-Stat ® Antistatic washable fiber fabric. It does not release fibers. Hood with elastic and velcro connection. Double slider protected zip. Elastic around cuffs and waist. Overshoes with elastic under-sole. Ventilated back. Little pocket, two front pockets and one back pocket.

Code	Size	Color
<b>610.1120</b>	M(46-48), L(50-52), XL(54-56), XXL(58-60)	White



## SPRAY-TECH™

DPI Categoria I.

Overall made of 100% polyester, extremely comfortable and transpirant, does not release fibers and it is washable many times. Hood with elastic and velcro connection. Double slider protected zip. Elastic around wrists, ankles and hips. Little pocket and back pocket with velcro connection.

Code	Size	Color
<b>610.1110</b>	M(46-48), L(50-52), XL(54-56), XXL(58-60)	Blu
<b>610.1111</b>	M(46-48), L(50-52), XL(54-56), XXL(58-60)	Bianca

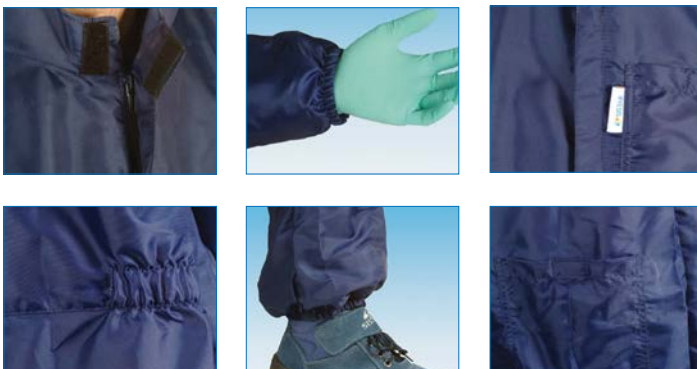





### COAT TECH

Coat made of 100% polyester transpirant and comfortable fabric, washable, with protective cap, little pocket and two pockets, connection with automatic buttons also on wrist. Suitable for polisher-man, for the decorator, painter and for work-bench man, for the warehouse and for all operators that require a fresh and practical cloth in order to protect themselves from dirt. PPE Cat. I.

Code	Color	Size	Pack.
610.1105	White	M(46-48), L(50-52), XL(54-56), XXL(58-60)	1 pcs.



### MICRO-SHIELD™

Overall with hood. Highly transpirant, it is ideal for use in very hot areas. Color: White. PPE Cat. III, Type 5-6.



Code	Color	Size	Pack.
601.0105	White	M, L, XL, XXL	25 pcs.



### POLIGARD® PLP

Overall made of polypropylene with hood. Very light and transpirant. Elastic around wrists, ankles and hips. Protected zip with flap, back pocket. Color: White. For generic use in non-hazardous areas. PPE Cat. I.

Code	Color	Size	Pack.
607.0100	White	M, L, XL, XXL	25 pcs.

## BODY-GUARD™

Overall with hood to protect the worker from hazardous substances. Ideal for painting in car-body shop. Silicone-free, does not release fibers, high resistance to strain. Internal seams, elastic around wrists, ankles and waist. Adhesive pocket to be apply in the point more comfortable for the user. Color: White. PPE Cat. III, Type 5-6, Antistatic.



Code	Color	Size	Pack.
603.0200	White	M, L, XL, XXL	25 pcs.

## BODY-GUARD PLUS™

Overall with hood and completely transpirant back. Particularly comfortable, it is ideal for painting in car-body shop during hot season. Silicone-free, does not release fiber. Internal seams, elastic around wrists, ankles and waist. Adhesive pocket to be apply in the point more comfortable for the user. Color: White. PPE Cat. III, Type 5-6, Antistatic.



Code	Color	Size	Pack.
603.0210	White	M, L, XL, XXL	25 pcs.



### TYVEK® DuPont™

Sewn overall, Classic original DuPont model, with hood. Used to protect the worker from dangerous substances. Silicone-free, minimum release of fiber, extremely light. Elastic around wrists, ankles and waist. Color: White. PPE Cat. III, Type 5-6, Antistatic.



Code	Color	Size	Pack.
603.0300	White	M, L, XL, XXL	25 pcs.



### TYVEK® CLOTHES DuPont™

Working clothes for general use, made of Tyvek 100% polyethylene. Color: White. For the partial protection of body in areas with light risk. PPE Cat. I.

Code	Description	Size	Pack.
603.0310	① Jacket with hood, elastic around wrists and waist	L, XL, XXL	50 pcs.
603.0320	② Trousers with elastic around waist	L, XL, XXL	50 pcs.
603.0330	③ Coat with velcro connection 3 pokets	L, XL, XXL	50 pcs.



### TYVEK® ACCESSORIES DuPont™

Working accessories for general use, made of Tyvek 100% polyethylene. Color: White. For the partial protection of body in areas with light risk. PPE Cat. I.



Code	Description	Pack.
603.0341	① Hood with round elastic around face and nape	100 pcs.
603.0350	② Shoe-cover with elastic around ankle	200 pair
603.0350.L	② Shoe-cover with elastic around ankle - Mis. L	100 pair
603.0349.XL	② Shoe-cover with elastic around ankle and PVC sole XL	200 pair
603.0351	③ Half sleeve with elastic on the 2 ends	100 pair

## VERNICLEANER™

Vigorous hands cleaning gel for painters. With natural extracts of citrus. Studied specifically for cleaning of hands by painting products, both solvent-based and water-based. It also eliminates persistent odors.

Code	Package	Pack.
571.8002	1 L con dosatore	12 pcs.
571.8003	3 L con dosatore	6 pcs.
576.8016	Supporto a parete per tanica da 3 L	1 pcs.



## MEC CLEANER™

Vigorous hands cleaning gel for mechanician. With natural extracts of citrus. Ideal for cleaning of hands by industrial dirt. It also eliminates persistent odors.

Code	Package	Pack.
571.8021	5 L con dosatore	4 pcs.



## STARSOAP™

Natural hands cleaning paste, white color, to remove industrial dirt. Contains lanolin for care and protection of skin. It does not contain sand or irritant and aggressive substances.

Code	Package	Pack.
573.8071	5 L (5 Kg ca.)	4 pcs.





### HAND CLEANER

Hands cleaning paste, beige color, to remove the industrial dirt. With lanolin for protection of skin. It does not contain sand or irritant and aggressive substances.

Code	Package	Pack.
573.8080	1 L	12 pcs.
573.8081	5 L	4 pcs.

### RIWAX®



### HAND-CLEAN

Hands cleaning cream, rapid action, deep and delicate. Ideal for cleaning of very dirty hands. Removes grease, oil, wax, bitumen, tar, inks, paints, adhesives, etc. Dermatologist tested, pleasant fragrance, contains specific substances for protection and care of skin, also in case of frequent use.

Code	Package	Pack.
784.2977	4 Kg	4 pcs.
576.8010	Dispenser	12 pcs.

### Kimberly-Clark PROFESSIONAL®



### WYPALL

Wet cloth for cleaning and protection in a portable pack, with a rough side to remove dirt and a smooth side for cleaning and polishing. Ideal for cleaning hands, tools and machines without soap, gel or water; this product protects your hands, reduces skin dryness and improves sanitation.

Code	Package	Pack.
152.7772	Barattolo-Dispenser da 50 panni 27x27 cm	6 pcs.



### CLEAN UP

Cleaning cloths impregnated with an effective detergent for cleaning surfaces, tools and equipments. It's particularly suitable for removing the sealant in excess used during the replacement of the plates and glasses. Used as hand-washing cloth, remove all kinds of hard dirt and odors without the use of soap and water due to its formula based on vegetable surfactants and durable non-woven fabric with a slightly rough side. It contains also antibacterial, glycerin and emollients to protect skin. Clean-Up can be used anywhere thanks to the pack portable and resealable to keep the damp cloths and sheltered from dust.

Code	Package	Pack.
152.5100	Barattolo-Dispenser da 70 panni 20x30 cm	6 pcs.



## FOULSTOP™

Dirt repellent action cream, oil-insoluble. Increases the natural protection of skin from aggressive action of oils, grease, hydrocarbons, etc. Prevents the adhesion of dirt to the skin and cleans easy with just water, without need to use soaps or detergents. The skin can breathe and it's possible use it on the arms, legs, face.



Code	Description
574.5101	Can of 500 ml = about 300 applications

## OLEO-PROTECTOR

Oily protective barrier cream. To increase the natural protection of skin from aggression of chemical agents as mineral and vegetable oils, grease of various nature, hydrocarbons and their derivatives, harmful substances. The skin can breathe.



Code	Description
574.5010	Tube of 100 ml

## SMOOTH PAPER TOWEL

Paper roll made of not recycled pure cellulose. Extra quality, double layer. Does not contain optical brighteners.



Code	Description	Color
575.8900	Roll of 800 sheets 26x38 cm - 3,5 kg about	White

## EMBOSSED PAPER TOWEL

Paper roll made of not recycled pure cellulose, double layer, extra quality. Embossed structure with honeycomb for better absorbency. Does not contain optical brighteners.



Code	Description	Color
575.8902	Roll of 800 sheets - 2,0 Kg about	White

**GROUND DISPENSER**

Ground support. Suitable for rolls  $\varnothing$  max. 60 cm, width max. 36 cm. Made of metal, white color.

Code	Size
576.8920	cm. 43x49x73 h.

**WALL DISPENSER**

Support for fixing to wall or work-bench. Suitable for rolls  $\varnothing$  max. 60 cm, width max. 30 cm. Made of metal, white color.

Code	Size
576.8921	cm. 39x34x24 h.

**TROLLEY**

Big and strong trolley Kimberly-Clark for paper or non-woven rolls, with rubbish bag.

Code	Size
576.6155	cm. 50x50x109 h.



PAGE 125-130

DOW Automotive Systems



Automotive Systems





Automotive Systems

**BETASEAL™ 1407****4 HOURS**

1K polyurethane adhesive and sealant that crosslinks in the presence of moisture, viscous, used for windscreen bonding and windows of car with AIRBAG. It's also an adhesive with a high mechanical resistance module, non-conductive with excellent compatibility with the waves of high frequency radio. BETASEAL 1407 must be used with BETACLEAN 3300 and BETAPRIME 5504G. The double kit contains 2 cartridges of BETASEAL 1407 + 1 disposable stick of 10 ml of BETAPRIME + 1 disposable towel of 8 ml of BETACLEAN 3300. Open time up to 15 minutes. Consult Technical Data Sheet.

Code	Color	Package	Pack.
730.1407.310	Black	Cartridge 310 ml	12 pcs.
730.1407.400	Black	Sausage 400 ml	12 pcs.
730.1407.KIT		DOUBLE KIT	12 pcs.

**BETASEAL™ 1507****2 HOURS**

1K polyurethane adhesive and sealant that crosslinks in the presence of moisture, very viscous, used for windscreen bonding and windows of cars with AIRBAG. It's also an adhesive of high mechanical resistance module, with low electrical conductivity and good compatibility with the waves of high frequency radio. BETASEAL 1507 must be used with BETACLEAN 3300 and with BETAPRIME 5504G. Open time up to 15 minutes. Consult Technical Data Sheet.

Code	Color	Package	Pack.
730.1507.310	Black	Cartridge 310 ml	12 pcs.

**BETASEAL™ 1580****30 MINUTES**

1K polyurethane adhesive and sealant that crosslinks in the presence of moisture, viscous, used for windscreen bonding and windows of cars with AIRBAG. The exclusive AINS technology (Accelerated Isotropic Network Structure) ensures extraordinary grip and resistance. It is also an adhesive to high mechanical strength of the module, with excellent compatibility with waves of high frequency radio. BETASEAL 1580 can be applied directly on the curb of old polyurethane just cut (no on polymer) without the need of primer or activator. The primer BETAPRIME 5504G must be applied always of glass. Open time up to 15 minutes. Consult Technical Data Sheet.



Code	Color	Package	Pack.
730.1580.310	Black	Cartridge 310 ml	12 pcs.
730.1580.600	Black	Bag 600 ml	12 pcs.



Automotive Systems

## BETASEAL™ 1590CT Adhesive “All In One”: bonding and sealing in one product

1K polyurethane adhesive and sealant for industrial and commercial vehicles applicable cold with 2 hours of the stationary vehicle. The exclusive technology AINS (Accelerated Isotropic Network Structure) ensures extraordinary grip and resistance. It's the choice better to replace the windshield, rear and side windows on commercial vehicles such as buses, coaches, trucks and trains. BETASEAL 1590CT™ can be applied directly to the curb of old polyurethane just cut (no on polymer) without primer or activator. The primer BETAPRIME 5504G instead must be always applied on glass. Open time up to 22 minutes. Consult Technical Data Sheet.



Code	Color	Package	Pack.
730.1590CT.600	Black	Bag 600 ml	12 pcs.

## BETAPRIME™ 5504G Primer “All In One”

Primer “All In One” - Activator + Primer + Anti UV Protective + Anticorrosive - for glass, ceramic screen printing, metal, old polyurethane bead, paint, encapsulated (PUR, PVC, PAAS).It must be used with all types of polyuretane adhesive BETASEAL and BETAPRIME. Very fast, dries in 2 minutes. New version “Not shake”, does not require shake. It not suitable for direct use on polycarbonate. Being a hygroscopic product, immediately close the bottle after each use and use within 2 weeks of first opening due to the relative humidity in the environment. Consult Technical Data Sheet.



Code	Color	Package	Pack.
730.5504G.125	Black	Bottle 125 ml	24 pcs.
730.5504G.250	Black	Bottle 250 ml	24 pcs.
730.5504G.10	Black	Disposable stick10 ml	24 pcs.

## BETABRADE™ ABRASIVE CLEANER

Water-based abrasive cleaner. Removes silicone from contaminated glass without damaging them. Consult Technical Data Sheet.



Code	Package	Pack.
730.BRADEF1.75	Bottle 75 ml	12 pcs.







Automotive Systems

**BETACLEAN™ 3300**

Cleaner for glass, ceramic frit, encapsulated (PUR-RIM, PVC) and pre-applied polyurethane (PUR PAAS). Composition of demineralized water. Colour: Light blue transparent. Consult Technical Data Sheet.

Code	Package	Pack.
730.3300.500	Bottle Spray 500 ml	12 pcs.
730.3300.5	Tanica da 5,0 litri	4 pcs.
730.3300.25	Fustino da 25,0 litri	1 pcs.
730.3300.8	Salvietta disposable 8 ml	50 pcs.

**BETACLEAN™ EASY-GO**

Resin sponge with excellent abrasive properties for the removal of contamination from silicone of glass used in aftermarket. BETACLEAN EASY-GO is used with the glass detergent BETACLEAN 3300.



Code	Size	Package
730.3300.EG	80X20X20 mm	224 pcs.

**APPLICATOR PAD**

Disposable applicator pad for Primer **U-PRIMER 130**.



Code	Pack.
304.0520.100	100 pcs.

**NOZZLES**

Spare nozzles for cartridge of sealents and 1K adhesives.

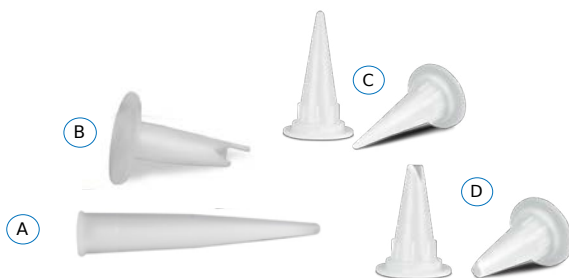

Code	Description	Pack.
304.0521.12	(A) Conical jet for cartridge	12 pcs.
304.0522.100	(B) Truncated conical jet with V cut for cartridge	100 pcs.
304.0523.100	(C) Conical jet for bag	100 pcs.
304.0524.100	(D) Truncated conical jet with V cut for bag	100 pcs.



Automotive Systems

## BETAFILL™ 10101

**SPRAYABLE**

1K sealant based POP without isocyanate that crosslinks in the presence of moisture. It's sprayable, highly adhesive and permanently elastic. Is characterized by excellent UV stability and can be overpainted immediately. BETAFILL™ 10101 allows to the coachbuilder to make repairs and sealing identical to original finishing. It can be painted after the time of making the skin in about 25/30 minutes. It is applicable with pneumatic gun SPRAYSEAL 300. Consult Technical Data Sheet.



Code	Color	Package	Pack.
730.10101.310	Grey	Cartridge 310 ml	12 pcs.

## BETAMATE™ 2090

2K epossidic adhesive designed for structural repairs and bonding of vehicles with OEM quality, including the rear wing and the door panels. Once applied, BETAMATE™ 2090 has a greater resistance to crash and a better energy absorption, providing the same levels of performance of structural assembly of the automakers producing. It also offers excellent corrosion protection in intersections and flanges. It is appropriate also for the bonding of composite materials. It is applicable with professional traditional supply gun with pushing piston. Consult Technical Data Sheet.



BETAMATE™ STRUCTURAL ADHESIVES  
OVER 7 BILLION METERS SOLD...

Codice	Colore	Confezione	Imballo
730.2090.195	Azzurro (in estrusione)	Cartuccia 195 ml + 3 mixer	46 pcs.
730.2090.MIX	BECCUCCIO-MIXER per cartuccia Betamate 2090		

## BETAPRIME™ 5404

Adhesion promoter for painted surfaces, plastic materials, fiberglass and polycarbonate. It must be used with polyurethane adhesives and sealants BETAFILL and BETASEAL of Dow Automotive Systems. Consult Technical Data Sheet.



Code	Color	Package	Pack.
730.5404.15	Black	Bottle 15 ml	24 pcs.
730.5404.250	Black	Bottle 250 ml	24 pcs.





Automotive Systems

**BETAFILL™ 10210**

1K polyurethane sealant very adhesive, permanently elastic that crosslinks in the presence of moisture. Is an excellent sealant for the repair of vehicles, which allows to paste, seal and putty. It can be sanded and compatible with almost all paint systems. It can be used as non structural adhesive for overlap. It can be painted after the time of making the skin in about 25/30 minutes. Consult Technical Data Sheet.

Code	Color	Package	Pack.
730.10210.310	White	Cartridge 310 ml	12 pcs.
730.10210.600	White	Sausage 600 ml	12 pcs.

**BETAFILL™ 10211**

1K polyurethane sealant very adhesive, permanently elastic that crosslinks in the presence of moisture. Is an excellent sealant for the repair of vehicles, which allows to paste, seal and putty. It can be sanded and compatible with almost all paint systems. It can be used as non structural adhesive for overlap. It can be painted after the time of making the skin in about 25/30 minutes. Consult Technical Data Sheet.

Code	Color	Package	Pack.
730.10211.310	Grey	Cartridge 310 ml	12 pcs.
730.10211.600	Grey	Sausage 600 ml	12 pcs.

**BETAFILL™ 10215**

1K polyurethane sealant very adhesive, permanently elastic that crosslinks in the presence of moisture. Is an excellent sealant for the repair of vehicles, which allows to paste, seal and putty. It can be sanded and compatible with almost all paint systems. It can be used as non structural adhesive for overlap. It can be painted after the time of making the skin in about 25/30 minutes. Consult Technical Data Sheet.

Code	Color	Package	Pack.
730.10215.310	Black	Cartridge 310 ml	12 pcs.
730.10215.600	Black	Sausage 600 ml	12 pcs.

**BETACLEAN™ 3350 RAPID CLEANER**

Degreasing detergent to remove dirt and grease from metal, plastic, paint, glass. Composition of Heptane. Pack. with aluminium bottle. Consult Technical Data Sheet.

Code	Color	Package	Pack.
730.3350.1000	Transparent	Bottle 1000 ml	12 pcs.



PAGE 131-148

SPRAY MAX



BACK TO  
INDEX



### Aerosol Technology

SprayMax is a professional spray can filled with original paints from automotive paint manufacturers. All painting steps outlined only refer to the use of aerosol cans.

SprayMax aerosol technology is based on two components:

1. SprayMax spraying and application technology featuring broad-jet atomization, high paint output quantities, constant spraying pressure (until the aerosol is completely empty) as well as even layer application, and minimal overspray.
2. Tested and approved original paints for a perfect painting result in combination with SprayMax technology.

#### Key features of SprayMax technology

- Innovative nozzle, valve and propellant technology
- High output quantity, fast working speed, broad-jet atomization
- 1K and 2K technology
- Professional painting results compared to a spray gun

### Comparison of spray patterns

#### A paint spray can changes the painting world

The benchmark in the professional painting world is the result achieved with a pneumatic spray gun. Up to a few years ago, no one believed paint spray cans could match the properties of pneumatic tools, as spray cans were seen as DIY articles. The market started developing alternative and cost-effective repair methods for which the suitable paint repair system was lacking – and this is where the patented SprayMax aerosol technology came into its own. Its years of success in the car paintwork repair field have allowed this revolutionary technology to gradually take over other painting applications. SprayMax achieves painting results that can hold their own with results achieved in paint workshops.

The core of our system is the revolutionary and multiple-patented SprayMax aerosol technology that produces a paint finish comparable to a spray gun. The combination of our special propellant formula and innovative spray head and valve technology produces a wide-angle spray similar to a spray gun, but with much less overspray resulting in excellent transfer efficiency.

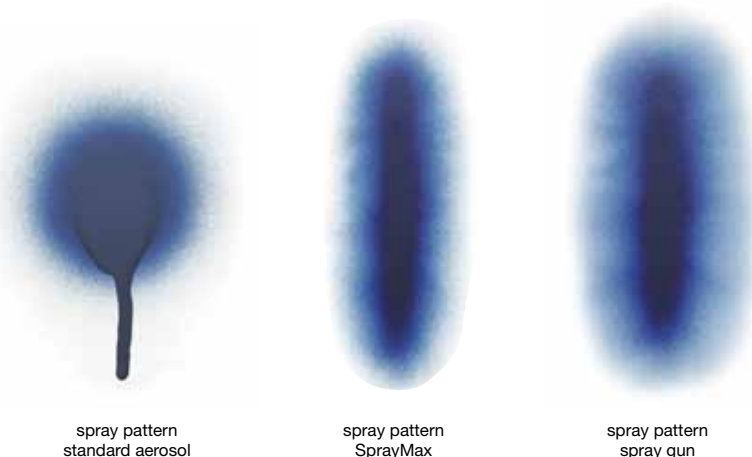





# Aerosol Technology

## 2K Technology



### Definition SprayMax 2-Component technology

- SprayMax 2-component technology means 2 components, paint and hardener, in one spray aerosol
- The hardener is integrated in a separate container
- The hardener is activated or released with the push of a button and mixed with the paint material
- The SprayMax 2K technology guarantees highest product and work quality just like with a spray gun in a paint shop

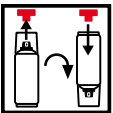
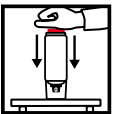
## 2K instructions for use

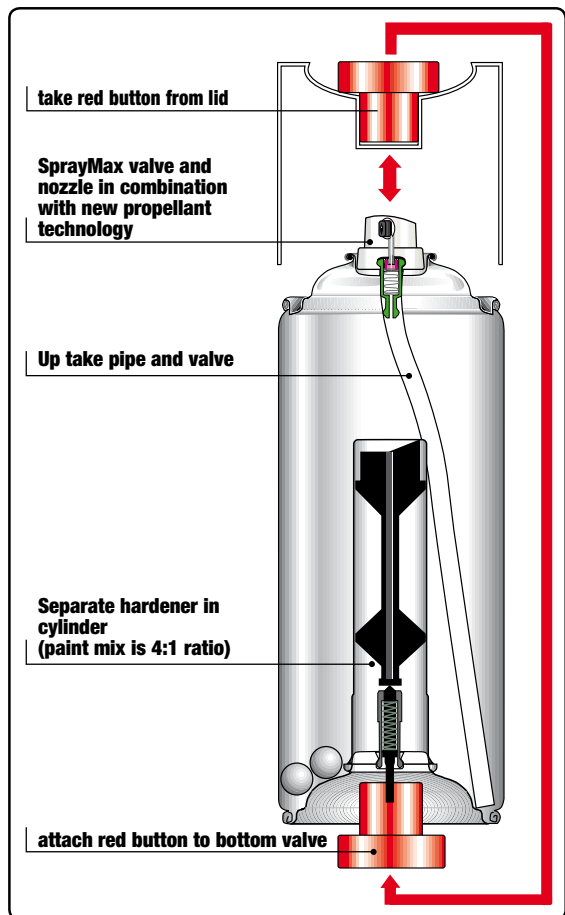
1. Check the item.  
Make sure that you have the right product. If the wrong product is accidentally activated, the aerosol will be useless if it is not subsequently used until the potlife.
2.  Thoroughly shake the aerosol for two minutes before from once you hear the agitator balls in the aerosol hitting off each other.
3.  Remove the red push button from the cap and place on the pin in the bottom of the aerosol without tilting it. Place the aerosol on a stable, horizontal surface with the cap pointing downwards.
4.  Activate the aerosol.  
Prime the aerosol by applying even, vertical pressure. Listen for a clicking noise. Please press just once.
5. Dispose of the red button in the trash so that you can tell activated aerosols from non-activated ones if using more than one aerosol.
6. Write the date and time of activation on the label.  
The pot life specified in the Technical Data Sheets applies at an ambient temperature of 20°C. The pot life will vary depending on the ambient temperature. Lower temperatures will extend the potlife, while higher temperatures will reduce it.

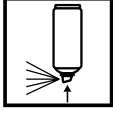

7.  Thoroughly shake the aerosol for two minutes to properly mix the activator with the paint.
8.  Perform a trial spray and check the product. When performing your trial spray, check whether the aerosol is spraying cleanly and evenly. For colour aerosols, check the colour.
9.  Clean the valve.  
When you are finished working you must empty the valve with the spray head pointing downwards. Spray until only propellant leaves the nozzle.



# Aerosol Technology

## SprayMax can equipment

### Variator spray nozzle

Spray nozzle can be steplessly adjusted horizontally, vertically and with regard to the size of the spray pattern (less overspray, less consumption, less masking work or follow-up work required).

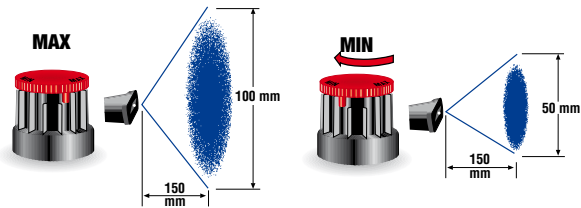

**Transparent cap**  
Replaces the coloured cap and allows the user to see the colour code ring.

**Colour code ring**  
Firmly fixed to the can (no risk of confusion e.g. as in the past when the coloured cap was lost or accidentally swapped).



**New colour code system**  
The SprayMax products are sorted into groups to match the processing steps and are also been colour coded (better overview / less risk of confusion / better arrangement of storage in the paint room).

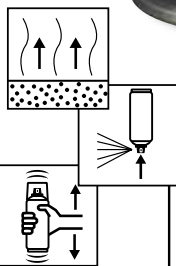

**Processing information / pictograms**  
The processing steps and the technical data are shown as pictograms directly on the label (faster overview of the technical data, as a supplement to the online technical information sheet).



# Aerosol Technology

## State of the market

### Spot-Repair, Smart-Repair, Clever-Repair, Paint-Repair?

The hottest catch phrases in automotive paint repairs over the last few years have been 'spot repair' and, most recently, 'smart repair'. Spot repair describes a method where only the immediate site of the damage is repaired. Lately, this term has come to cover many cosmetic repairs and various other kinds of repairs (to car seats, dashboards etc.). Even though this market clearly displays worthwhile potential, spot repairs mostly remain the domain of newcomers to the market.

Our core competence is the production of professional aerosols that facilitate quick and easy, yet professional, paint repairs. SprayMax allows you to carry out small paint repairs at low cost.

With the SprayMax PaintRepair system, you can target customers who, in many cases, wouldn't bother with a conventional paint repair job because of the cost involved.

The consequence: The customer drives away, not wanting to have to pay for an expensive paint job - you lose a potential sale.

SprayMax aerosols are ideal for small to medium paint repair jobs on "visible" objects or large areas, for example bumpers and side panels.

Furthermore SprayMax makes possible the bodywork subject enterprises extend your business fields by the area of paintwork and commercialize small damage repair as a new service.

Our solution: SprayMax PaintRepair.

## Application area

### Up to 50% savings on process costs in comparison with a spray gun using the SprayMax PaintRepair System



**Area A:**  
A paint repair job using SprayMax is perfect in this area.



**Area B:**  
A paint repair job using SprayMax is possible in this area depending on requirements and the experience of the repairer.

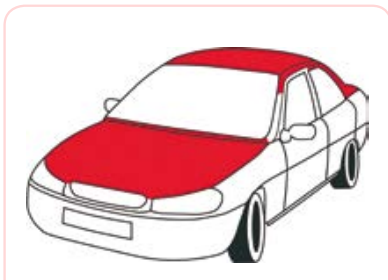

**Area C:**  
A paint repair job using spray cans is not practical in this area.

Source: Allianz Zentrum für Technik GmbH - Division Motor Vehicle Technology



## Automotiv Coatings

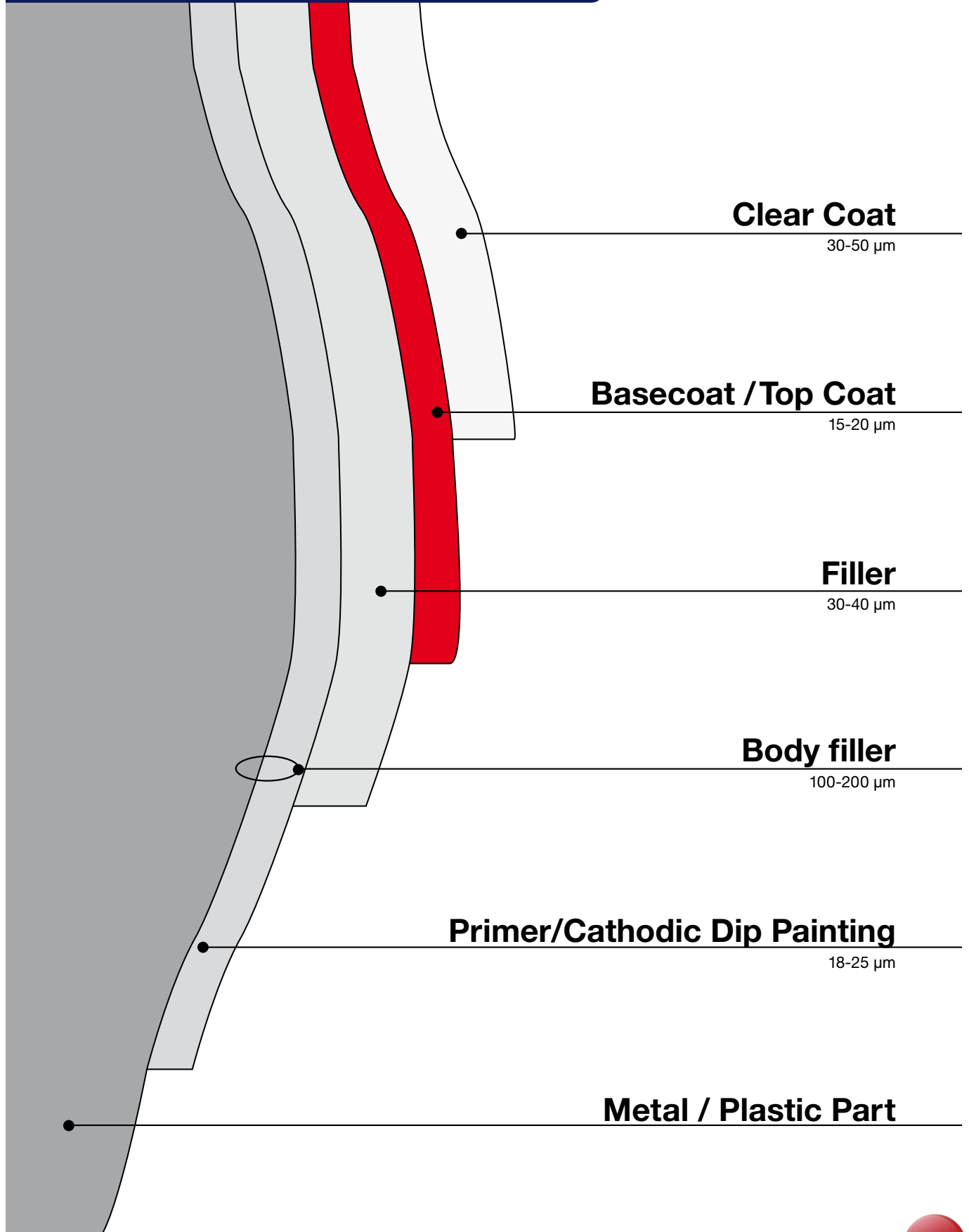



**Perfect Coating**

at low  
Process Costs



**Blending Clear**

e.g. Clear coat



Clear coats and  
spot-blenders



**Sealers**

FillClean® / Fill In System



Top coats

Basecoats and  
top coats



**Filler**

e.g. Acrylic filler



Fillers



**Body filler**

e.g. Body filler



Body filler



**Primer**

e.g. Ant-Corrosion primer,  
Epoxy primer filler



Primers / fillers



**Pre-Treatment**

e.g. Silicon remover, Antistatic spray,  
Plastic adhesion promoter



Surface  
preparation







### SILICON REMOVER

Rich in active ingredients, mild cleaning agent for the efficient removal of silicone, grease, oil, wax, dirt, tar, and soot. This high quality silicone remover has excellent cleaning and degreasing properties and improves the adhesion to any paint coat. The product is used for the application of solventbased paints.

Code	Color	Package	Pack.
750.680 090	Transparent	400 ml	6 pcs.



### AQUA SILICON REMOVER

Water-borne cleaning agent, rich in active ingredients and with a reduced solvent content. Ideal for the removal of silicone, grease, oil, wax, dirt, tar, and soot. This high quality product improves the adhesion to any paint coat and reduces the electrostatic effect. High cleaning and degreasing properties. The product is used for the application of waterborne basecoats.

Code	Color	Package	Pack.
750.680 094	Transparent	400 ml	6 pcs.



### 1K PLASTIC ADHESION PROMOTER

Ideal adhesion promoter for subsequent coatings on most plastics (see Technical Data Sheet).

Code	Color	Package	Pack.
750.680 009	Light silver	400 ml	6 pcs.

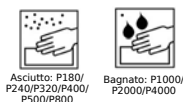
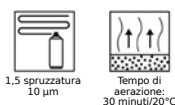
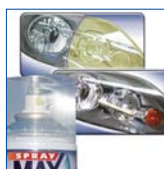

### 1K HEADLIGHT PRIMER

Water-based, colourless one-component primer (250 ml), specially developed for the repair of automotive headlight diffusion panels made from polycarbonate.

- Generates the ideal substrate for the subsequent protective layer formed by the 2K Head-light Clearcoat.
- Excellent adhesion properties
- High elasticity and fast drying
- Does not affect the translucency of the headlight

Code	Color	Package	Pack.
750.684 098	Transparent	250 ml	6 pcs.



## 1K ANT-CORROSION PRIMER

Corrosion protection primer with very good adhesion properties. Suitable for bare, sanded and unsanded surfaces. Cannot be retouched with polyester materials.

### Advantages

- Excellent corrosion protection
- Very good adhesion
- Welding test certificate: "repels" welding beads
- Can also be used on paint coatings



Code	Color	Package	Pack.
750.680 001	Red brown	400 ml	6 pcs.

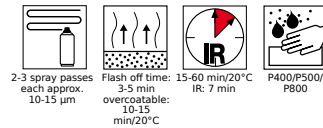

## 2K WASH PRIMER

2 component primer for fast insulation of sanded-through areas as part of car repair paintwork. For cleaned and sanded surfaces such as steel, aluminium, hardened surfaces, 2K surfacer compounds and old paintwork.

Code	Color	Package	Pack.
750.684 029	Olive-grey	250 ml	6 pcs.



## 2K RAPID PRIMER FILLER

Universal, quick-drying 2K primer for high-quality automotive paint jobs. Ideal for partial paint jobs and spot repairs.

Code	Color	Package	Pack.
750.684 031	Grey	250 ml	6 pcs.
750.680 031	Grey	400 ml	6 pcs.

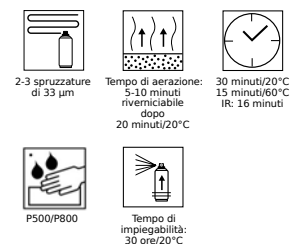

## 2K EPOXY PRIMER FILLER

Universal 2K epoxy primer filler for all problematic surfaces, for example metal, non-ferrous metal, galvanized sheet steel, or anodized aluminium.

Code	Color	Package	Pack.
750.680 032	Beige	400 ml	6 pcs.
750.680 033	Grey	400 ml	6 pcs.
750.680 034	Black	400 ml	6 pcs.

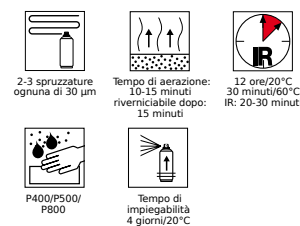



**ALSO  
ADHESION ON  
PLASTICS**



2-3 spruzzature  
ognuna di 20 µm



Flash off time: 5 min  
riverniciabile dopo:  
10/15 min 20°C



15 min/20°C  
IR: 3 min



P400/P500/  
P800

### 1K AC FILLER

Acrylic filler with good stability, faster drying and excellent dry-sanding properties. Ideal for spot repairs. Can be used on steel, galvanised steel, aluminium and various plastics.

Code	Color	Package	Pack.
<b>750.680 280</b>	Light grey	400 ml	6 pcs.
<b>750.680 281</b>	Dark grey	400 ml	6 pcs.
<b>750.680 282</b>	Medium grey	400 ml	6 pcs.

### 2K ACRYLIC FILLER

Professional very fast-drying filler with excellent filling capacity, outstanding flow, and very effective isolation for old paint jobs. Can be used for middle surfaces. Preprime large sanded-through spots, for example using filler primer.



2-3 spruzzature  
ognuna di 20 µm



Tempo di aerazione:  
5-10 min  
riverniciabile dopo:  
10-15 min/20°C



3-4 ore/20°C  
IR: 25 min



P600/P1000/  
P800/P1200



Tempo di  
impiegabilità  
24 ore/20°C

Code	Color	Package	Pack.
<b>750.684 036</b>	Grey	250 ml	6 pcs.
<b>750.680 036</b>	Grey	400 ml	6 pcs.



## 1K PRIMER FILLER “Primer Shade”

1K Primer Filler Primer Shades form a system of 1K primer surfacers ranging from white to black. By choosing a level of grey which matches to the brightness value of the successive topcoat hiding will be met earlier. Expensiv e topcoat paint can be saved and the painting process will be shortened.

- 1-component etch primer
- Simple and time-saving application
- Excellent corrosion protection
- Even application and good flow
- Can also be applied wet-on-wet
- Fast drying
- Can be overcoated with waterborne basecoats

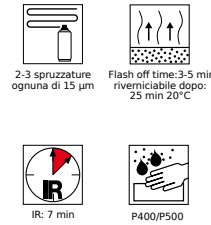

Ridotti consumi di vernice e tempi di lavorazione rapidi grazie alla tonalità ottimizzata per la finitura.

Code	Color	Package	Pack.
750.680 271	White	400 ml	6 pcs.
750.680 272	Light grey	400 ml	6 pcs.
750.680 274	Grey medium	400 ml	6 pcs.
750.680 276	Dark grey	400 ml	6 pcs.
750.680 277	Black	400 ml	6 pcs.
750.680 278	Beige	400 ml	6 pcs.

## 1K UNIFILL

- Primer-filler for insulation of sanded-through areas with high filling power
- For use direct on steel, galvanized steel, aluminium and various plastics
- High filling capacity
- Fast drying
- Good stability
- Good active corrosion protection
- Can be painted over with water-based paints

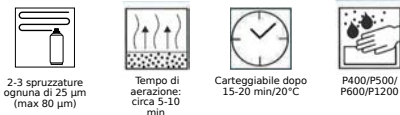

Code	Color	Package	Pack.
750.680 410	S2 - Light grey	500 ml	6 pcs.
750.680 411	S4 - Grey medium	500 ml	6 pcs.
750.680 412	S6 - Dark grey	500 ml	6 pcs.
750.680 413	S8 - Black	500 ml	6 pcs.





ALSO  
VERSION  
MATT



1-3 spruzzature  
ognuna di 10-15 µm



Tempo di aerazione:  
5-10 min/20°C



12 ore/20°C  
60 min/60°C  
IR: circa 7 min

### 1K CLEAR COAT

1K clear coat for quick coating and longterm sealing of repair paint jobs and new paint jobs on cars and motorcycles.

#### Advantages

- Easy to use
- Dries quickly
- High gloss level (Art.No.: 680 051)
- No colour deviation
- Good weathering resistance
- Very good flow
- Very good polish ability

Code	Color	Package	Pack.
750.680 050	Transparent matt	400 ml	6 pcs.
750.680 051	Transparent brillante	400 ml	6 pcs.



1-2 spruzzature  
ognuna di 30 µm



Tempo di aerazione:  
10-15 min/20°C



12 ore/20°C  
40 min/60°C



Tempo di  
impiegabilità  
48 ore/20°C

### 2K CLEAR COAT Transparent

2K clear coat with very high chemical, gasoline, and weathering resistance for high-quality and longterm sealing of repair paint jobs and new paint jobs on cars and motorcycles.

#### Advantages

- Maximum resistance to abrasion and scratching
- Very smooth flow
- Lasting high gloss
- Very good polish ability
- No colour deviation
- Outstanding painting surface
- Suitable even at higher ambient temperatures
- Ideally suited for large surfaces

Code	Color	Package	Pack.
750.680 061	Transparent brillante	400 ml	6 pcs.



2 spruzzature  
ognuna di 15 µm



Tempo di aerazione:  
5 min/20°C



60 min/20°C  
30 min/60°C  
IR: circa 15 min



Tempo di  
impiegabilità  
14 ore/20°C

### 2K RAPID CLEAR COAT

2K clear coat with very short drying time and very high chemical, gasoline and weathering resistance for high quality and longterm sealing of repair paint jobs and new paint jobs on cars and motorcycles. Ideally suited to spot repairs.

#### Advantages

- Maximum resistance to abrasion and scratching
- Very smooth flow
- Lasting high gloss
- Very good polish ability
- No colour deviation
- Outstanding painting surface
- Suitable even at higher ambient temperatures
- Ideally suited for large surfaces

Code	Color	Package	Pack.
750.684 064	Transparent brillante	250 ml	6 pcs.

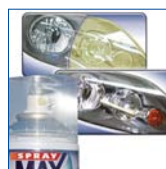

2 spruzzature



Tempo di aerazione:  
2 min



IR: 25-30 min



Tempo di  
impiegabilità  
14 ore/20°C

### 2K HEADLIGHT CLEARCOAT

Repair of auto motive headlight diffusion panels. Highly transparent, UV- and weather resistant two-component clearcoat (250 ml) for the mending of automotive headlights made from polycarbonate. 2K Headlight Clearcoat. Wide jet spray (spray pattern analogue to a spray gun). High paint coverage. Constant jet pressure maintained until the can is completely empty. Professional painting results.

Code	Color	Package	Pack.
750.684 066	Transparent brillante	250 ml	6 pcs.





## SPRAYMAX HEADLIGHT KIT

Special water-based aqua-adhesion agent (adhesion primer) for repairing polycarbonate headlamp lenses. Excellent adhesion properties. High elasticity. Fast drying. Does not impair transparency. Forms an ideal surface for subsequent protective coating with 2K headlamp clearcoat Art.No. 684 066.

### Headlight repair set

1x 250 ml 1K Headlight primer  
1x 250 ml 2K Headlight clearcoat



Code	Color	Set	Pack.
750.684 099	Transparent	2x250 ml	3 pcs.

## HARMONIZING - BLENDER CLEAR

Blender clear is a special product for homogenous paint transitions in the touch up areas for 1K / 2K clear coats, and 2K clear coats with very good blending results. Use the blender clear right after the clear coat application. Smooth edge areas in blender paint area. Very good partial dissolving properties. No colour tone deviations. Dries glossy. Ideal for repair painting and spot repairs.



Code	Color	Content	Pack.
750.680 092	Transparent	400 ml	6 pcs.



1 light spray pass



12 ore/20°C  
IR: circa 15 min

## RESIN HARMONIZING - BLENDER THINNER

Blender thinner is a special product for homogenous paint transitions in the touch up areas for 1K / 2K clear coats and 2K clear coats with outstanding blending results. Use the blender thinner right after the clear coat application. Smooth edge areas in blender paint area. Outstanding partial dissolving properties. No colour tone deviations. Dries matt, must be polished. Ideal for repair painting and spot repairs.



Code	Color	Package	Pack.
750.680 093	Transparent	400 ml	6 pcs.



1 light spray pass



12 ore/20°C  
IR: circa 15 min

## 1K WHEEL SPRAY

Highly resistant wheel spray with high yield for new and used wheels. Simple, time saving application. Fast drying. Resistant against stone impacts, road salt and brake dust



Code	Color	Package	Pack.
750.680 040	Silver	400 ml	6 pcs.



2-3 spruzzature  
ognuna di 15-20 µm



Tempo di aerazione:  
5 min/20°C



3 ore/20°C





2-3 spruzzature  
ognuna di 15-20 µm



Tempo di aerazione:  
1-5 min/20°C



24 ore/20°C

### 1K TEXTURED PAINT

Special product for the reproduction of a ashlar and textured surface in the car market, especially for plastic bumpers. It can be over-painted with all 1K and 2K paints.

Code	Color	Package	Pack.
750.680 012	Transparent - medium grit	400 ml	6 pcs.
750.680 013	Transparent - great grit	400 ml	6 pcs.
750.680 180	Black	400 ml	6 pcs.

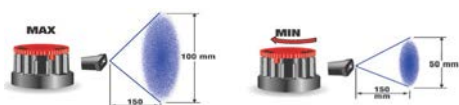

### VARIATOR SET

The special variable sprayer of SprayMax is usable for various products of the Spray-max system. It aims to optimize of the spray fan to fit perfectly to the surface to be painted. Thanks to the variator is possible to change the fan, horizontal or vertical, narrower or wider. It is possible to use a lot of times cleaning it with the detergent Spray-Max for guns (cod. 680 095).

Code	Description	Package
750.746 204	Variators kit - red/black	6 pcs.
750.746 211	Universal variators kit - blu/white	6 pcs.



### AEROSOL HAND-GRIP

Aerosol hand-grip for easy handling when painting with SprayMax or other aerosol products. The handle enables you to paint difficult-to-access areas, for example the inner edges of the door step area. Easy to use and makes your work easier. Increases painting accuracy. Does not influence or disrupt the spray pattern. Comparable to painting with a paint spray gun.

Code Sistar	Code SprayMax
306.0200	750.746200



### SPRAY GUN CLEANER

Special cleaning for effective cleaning of spray guns. Can be used universally for 1K solvent-based and 1K water-based paints and for unhardened 2K paints. The short and long nozzles allow residual-free cleaning of the paint gun without having to dismantle it. Ideally suited for fast cleaning of the Variator spray head.

Code	Color	Package	Pack.
750.680 095	Transparent	400 ml	6 pcs.



## 1K FILLCLEAN® FOR 1K SOLVENT BASECOATS

For the colour tone specific filling with solvent-based 1K basecoats in the brand and quality of the paint manufacturers named below or other solvent-based paint systems. The result is a ready to use SprayMax 1K paint spray can with



**306.0245**  
FillCap  
(supplied separately)

### 1K FillClean® for 1K solvent basecoats

Produttore	Serie della vernice	Serie A	Serie C		Codice Sistar
Spies Hecker	Permaflex KH vernice di copertura serie 530		682074		
Spies Hecker	Vorlack 293/295	682070			
		680070			
Standox	Basecoat	682070			
		680070			
Standox	Multimix KH vernice di copertura		682074		
Universal	per tutti gli altri sistemi di vernici a base di solvente			682071	306.0190
				680071	306.0192

Codice articolo per la versione FillClean® con cappellotto FillCap montato

### 1K FillClean® for 1K solvent basecoats





**306.0245**  
FillCap  
(supplied separately)

### 1K FILLCLEAN® FOR 1K WATER-BORNE BASECOATS

For the colour tone specific filling with water-borne based 1K paints in the brand and quality of the paint manufacturers named below. The result is a ready to use SprayMax 1K paint spray can with a water-borne based paint in the required colour tone. The very highest product quality and results are guaranteed. The very highest product and result quality are guaranteed. The SprayMax FillClean / Fill In can has its own paint-specific formulation and is therefore ideally tuned to the respective paint systems of the various paint manufacturers on the market.

#### 1K FillClean® for 1K water-borne basecoats

Produttore	Serie della vernice	Serie A	Serie B	Serie C	Serie D	Serie E	Marchio del produttore
De Beer	Serie 900 Waterbase			682077			
				680077			
DuPont Refinish	Cromax			682077			
				680077			
DuPont Refinish	Cromax Pro					682355	
						680355	
Glasurit	Serie 90			682077			
				680077			
Helios	Mobihel Hydro	682075					
		680075					
Lechler	Hydrofan				682078		
					680078		
Lesonal	Vernice di base WB						961503
MaxMeyer	AquaMax				682078		
					680078		
MIPA	WBC	682075					
		680075					
Nexa Autocolor	Aquabase				682078		
					680078		
PPG	Envirobase				682078		
					680078		
RM	Onyx HD			682077			
				680077			
Sikkens	Autowave MM		682076				
			680076				
Spies Hecker	Permahyd vernice di base serie 280/285	682075					
		680075					
Spies Hecker	Permahyd Hi-Tec 480					682355	
						680355	
Standex	Standohyd Basecoat	682075					
		680075					
Standex	Standoblue					682355	
						680355	
Palini	Hydropal						

Codice articolo per la versione FillClean® con cappellotto FillCap montato





## 2K FILL IN FOR 2K SOLVENT-BASED TOP COATS

For the colour tone specific filling with solvent-based 2K top coats in the brand and quality of the paint manufacturers named below. The result is a ready to use SprayMax 2K paint spray can with a 2K solvent-based top coat in the required colour tone. The very highest product quality and results are guaranteed. The cleaning-free cap is required to fill the 2K Fill In for 2K solvent-based top coats with the new FillClean filling device. The set of 6 caps should be ordered at the same time (Art.No. 990 246). The pot-life and processing time of the final product vary depending on the manufacturer and product.



### 2K FillClean® for 2K solvent basecoats

Produttore	Serie della vernice	Serie E	Serie F	Serie G	Serie G 250ml	Serie H	Serie I	Serie M	Marchio del produttore
<b>High Solid</b>									
DuPont Refinish	Imron Elite			680 086					
DuPont Refinish	Imron Elite HDC			680 086					
DuPont Refinish	Centari 5035		680 085						
Glasurit	2K CV Topcoat Reihe 58, 68								958 510
Glasurit	HS Vernice di copertura Reihe 22							680 312	
Lesonal	HS 420								961 502
Lesonal	CT Super Thane 2K S2000 Topcoat					680 088			
MaxMeyer	UHS Duralit Extra Series 110; Series 150	680 084							
Nexa Autocolor	P 471, P 472 2K-HS+vernice di copertura uni	680 084							
Nexa Autocolor	P 494, P 498 Turbo Plus EHS, vernice di copertura acrilica 2K	680 084							
PPG	PPG Delfleet 2K UHS vernice di copertura			680 086					
RM	UNO HD							680 312	
Selemix	Selemix 7-53X PUR Direct						680 089		
Sikkens	Combo LV								961 600
Spies Hecker	Permasolid HS Autolack 275			680 086	684 086				
Spies Hecker	Permasolid HS , vernice di copertura 670			680 086	684 086				
Spies Hecker	Permasolid HS Vario vernice di copertura 675			680 086	684 086				
Standox	Standocryl VOC Autolack			680 086					
Standox	Standofleet 2K-HS serie di vernice di copertura			680 086					
Standox	Standofleet 2K-HS serie di vernice di copertura a strato spesso			680 086					

Produttore	Serie della vernice	Serie A	Serie B	Serie K	Serie N
<b>Medium Solid</b>					
DuPont Coating S.	PercoTop PUR 2K MS vernice di copertura				680 313
Lesonal	2K Topcoat Uni vernice miscelata		680 083		
Sikkens	2K Autocryl vernice di copertura		680 083		
Spies Hecker	vernice di copertura 2K 257, 620	680 080			
Standox	2K Standocryl	680 080			
Spies Hecker	2K PUR vernice di copertura serie 570			680 310	
Standox	Multimix 2K PUR vernice di copertura			680 310	



**306.0245**  
FillCap  
(supplied separately)



# Liquid Gum

## Film sprayable



### The removable spray film in the original quality Auto-K

The Liquid Gum Spray helps you to create a highquality coating for protection, decorative or design purposes on your car or a wide range of other objects: and the clever thing is, the spray creates a paint-like protective film that can be peeled off easily at any time. New exciting design possibilities whenever you want.

- Protection and insulation
- Outstanding adhesion
- Abrasion and stone chip resistant
- Non-slip surface (grip)
- For car, house, handcraft and hobby
- For indoor and outdoor use
- Highly tear resistant when peeling off

YouTube



<https://www.youtube.com/watch?v=J3oLyojAtiQ>



### Classic colors

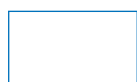

Transparent  
cod. 233 256



White  
cod. 233 251

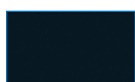

Black  
cod. 233 250



Bright blue  
cod. 233 252



Neon pink  
cod. 233 253



Neon green  
cod. 233 254



Neon Orange  
cod. 233 255

### Bright colors/ neon

A white (Liquid Gum white cod. 233251) or a white substrate, you need to get the shining effect.

The colors in the images are not binding and may change for technical printing reasons.

**Attention! Do not use products containing solvents, e.g. degreaser (petroleum benzine).**



**RIWAX®**  
beauty for cars

**RX 20 SPRAY FINISH**

**DE:** Sprühreiniger. Enthält auch Konservierungsstoffe. Auf allen Oberflächen. Reinigt ohne Wasser. Entfernt Fingerabdrücke, schützt den Glanz. Einfache und schnelle Aushilfe für Plexi- und Acrylglas.

**Anwendung:** Spray Finish aufsprühen, mit Wasser nachwischen.

**Hinweis:** Vor Gebrauch schütteln. Nicht verarbeiten. Lagerung: bei + 4° C.

**Zusammensetzung:** Enthält: Duftstoffe, Konservierungsstoffe, Methylchloro- / Methylisothiazolinone.

**FR:** Nettoyant en spray. Contient des conservateurs. Utilisable sur toutes les surfaces. Nettoie sans eau. Produit qui minimise les traces de doigts et protège le nouvel éclat. Utilisation simple et recommandée pour le plexiglas et le verre.

**Mode d'emploi:** Vaporiser le Spray Finish, essuyer avec un chiffon microfibre.

**Indications:** Agiter avant utilisation. Ne pas utiliser sur les surfaces sensibles. Stockage: de 4° C à 30° C.

**Composition:** Contient des substances aromatisées, des agents conservateurs (Méthylchloro- / Methylisothiazolinone).

**RIWAX Chemie AG**  
Tannholzstrasse 9  
CH-3052 Zollikofen  
Tel. +41 (0)31 910 45 45  
www.rwax.com

Made in Switzerland

e 5l

 **SISTAR**

PAGE 149-176

**RIWAX LINE**



**RIWAX®**



# PX

 professional surface finishing

## PX 100

The high performance polishing paste PX 100. Removes scratches of 1,500-3,000 grit and spray marks. High gloss effect. Can be used on all new and hardened finishing paint. Dark colours can be given a final polish using PX 200. Apply manually or by machine. Ideal to remove paint defects with 2Step System SRD Sistar Removing Defect (see pag. 176).

Code	Package	Pack.
780.1420	500 g	8 pcs.



## PX 200

The high gloss polish PX 200. Permanently removes fine scratches, holograms and smearing. Creates a deep shine. Suitable for removing minor car wash scratches (in one go during vehicle valeting). Apply by machine.

Code	Package	Pack.
780.1421	500 g	8 pcs.



## PX 300

The high-grade Carnauba paint protection PX 300 with long time protection. Lasting surface protection. Produces a brilliant deep shine. No marks or residues on synthetic surfaces. Simple application for vehicle valeting. Apply manually or by machine.

Code	Package	Pack.
780.1422	1 L	4 pcs.



## KIT PX Professional Surface Finishing

PX kit with:

- 1 PX 100 cod. 780.1420
- 1 PX 200 cod. 780.1421
- 1 PX 300 cod. 780.1422
- 1 blue pad diam. 175x30 mm cod. 785.11570-M
- 1 white pad diam. 175x30 mm cod. 785.11571-M
- 1 black pad diam. 175x30 mm cod. 785.11572-M
- 1 microfiber bonnet cod. 785.11575
- 1 wool disc diam. 165 mm cod. 785.11576-M
- 1 adapter diam. 150 mm for wool disc cod. 785.11577-M
- 1 blue microfiber cloth cod. 785.3476
- 1 case cod. 910.2035

Code
780.1429.KIT

**RX**  
CAR REFINISHING

**RX 01 COMPOUND FORTE**

Polishing out sanding marks as from 1000 grit sandpaper. For paint shops and for the preparation of used cars. Safe on all paintwork. Silicone free, VOC 15,1%.



Code	Package	Pack.
780.1408	1 Kg	4 pcs.

**RX 02 COMPOUND MEDIUM**

Polishing out traces from 1200 to 1500 grit sandpaper, in cases of heavy oxidation, orange peel, safe on alla paints. Silicone free, VOC 23,7 %.



Code	Package	Pack.
780.1402	1 Kg	4 pcs.

**RX 04 COMPOUND FINE**

Polishing out traces from 2000 to 3000 grit sandpaper (with fleece, up to 1500 grit), fast and clean, safe on all paintwork, also suitable for plexiglass and acrylic glass. Silicone free, VOC 23,7 %.



Code	Package	Pack.
780.1400	1 Kg	4 pcs.

**RX 06 ABRASIVE ANTI-HOLOGRAM POLISH**

Removes slight scratches (with fleece up to 3000 grits). High gloss. For rapid processing of vehicles. Also suitable for plexiglass and acrylic glass. Silicone free, VOC 0%.



Code	Package	Pack.
780.1403	1 Kg	4 pcs.



# RX

CAR REFINISHING



### RX 08 STAR FINISH

For finishing and waxing. Lasting protection. Can be used with an orbital or hand polisher. No osmosis with synthetics, no hologram traces. Silicone free.

Code	Package	Pack.
780.1404	1 L	4 pcs.



### RX 20 SPRAY FINISH

Spray cleaner. Contains selected preservatives. Suitable for use on all surfaces. Cleans without water. Aid for removing polish. Removes fingerprints, protects. Adds new sheen. Quick and easy to use, also suitable for plexiglass and acrylic glass. Solvents free, VOC 2,0%.

Code	Package	Pack.
780.1406.05	0,5 L con sprayer	8 pcs.
780.1406.5	5 L	4 pcs.



### RX 21 SPRAY FINISH

Spray cleaner. Contains selected preservatives. Suitable for use on all surfaces. Cleans without water. Suitable for use on all surfaces. Clean without water. Aid for removing polish. Removes fingerprints, protects. Adds new sheen. Quick and easy to use, also suitable for plexiglass and acrylic glass. Silicone free.

Code	Package	Pack.
780.1411.5	5 L	4 pcs.



### RX 00 MAT PASTE

Water-based matting abrasive paste to make mat and overpaintable the area between old and new paint. Apply by hand with Star Line Fiber Sistar. Silicone and solvents free, VOC 0%.

Code	Package	Pack.
780.1401	1 Kg	4 pcs.





**CLEAN CLAY CLOTH**

Microfiber cloth with 1 abrasive clay side, cleaning and polishing. Use with **RX 21 Spray Finish** to remove from car-body and from painted surfaces atmospheric dirt, industrial pollution, paint spray residues, dust of rust, bird droppings. After use is necessary use a dry and clean microfiber cloth in order to clean the surface without any dirt and contamination, smooth and shiny. If used with **Glas-Car Riwax** (cod. 783.2150) removes splashes of tar, bitumen, resin and glue residues. Do not use in direct sunlight and at temperatures exceeding 40 ° C.



Code	Size
785.5602	cloth 30x32 cm - argilla 26x28 cm circa

**RX CLEAN CLAY**

Removes deposits such as rust film, paint spray residue, other residues. Problem-solver for painted surfaces. Use with RX 20/ RX 21 and wipe with microfiber cloth.



Code	Package
785.5595	200 gr

**MICROFIBER CLOTH**

Cleans thoroughly and leaves no streaks, for interior and exterior use, can be used wet or dry. Size: 40x40 cm.



Code	Color	Package
785.3476	Blue	50 pcs.
785.3477	Light blue	50 pcs.





### WHITE PASTE-RS

Polishing abrasive paste, hydro compatible, usable on all surfaces. Apply by hand or by machine. Removes scratches and gives new brilliance to the gelcoat. Silicone and solvents free.

Code	Package	Pack.
786.11021	1 Kg	4 pcs.



### RS-01 COMPOUND FORTE

Extra-mordant abrasive paste, water based for gelcoat and fiber-glass heavily washed-up from weathering. Removes sanding scratches with grit P800-P1200. Silicone free.

Code	Package	Pack.
786.11000	1 Kg	4 pcs.



### RS-02 COMPOUND MEDIUM

Medium abrasive paste, water based to renew the brilliance of paint and gelcoat lightly washed-up from weathering. Removes the irregularity of old and sheltered gelcoat. Suitable after sanding with grits P1500-P2000. Silicone free.

Code	Package	Pack.
786.11001	1 Kg	4 pcs.



### RS-04 COMPOUND FINE

Fine abrasive paste, water based to renew the brilliance of paint and gelcoat lightly washed-up from weathering. Removes the irregularity of old and sheltered gelcoat. Suitable after sanding with grit P2000 (blue pad) up to P1500 (lamb bonnet). Silicone free.

Code	Package	Pack.
786.11002	1 L	4 pcs.



**RS-06 ANTI-HOLOGRAM ABRASIVE POLISH**

Anti-hologram abrasive polish, water based with high cleaning property. Suitable for gelcoat, paints, plexiglass, acrylic glass and polycarbonate. Suitable also for dark colours. Silicone and solvent free.



Code	Package	Pack.
786.11003	1 Kg	4 pcs.

**RS-08 STAR FINISH**

Water based polish for perfect finishing with long lasting effect. Apply by orbital machine and by hand. Particularly suitable for processing of new boats. Not scratches the plastic parts and doesn't leave hologram. Silicone free.



Code	Package	Pack.
786.11004	1 L	4 pcs.

**RS-20 SPRAY FINISH**

Rinse cleaner, water based, polishes and cleans without water. Easy and fast to apply. Suitable to use as finishing product. Usable on all surfaces, also on glass. Solvent free.



Code	Package	Pack.
786.11006.5	5 L	4 pcs.

**WAX-SHAMPOO-RS**

Removes grease and oil from gelcoat or paint without damaging the surface. Gives brilliance with every wash. Solvent free.



Code	Package	Pack.
786.11023	1 Kg	4 pcs.





### BOAT-CLEAN-RS

Universal cleaner for boats. Suitable for engine cleaning. Good cleaning power without damaging the brilliance. Does not form emulsions. Solvent free.

Code	Package	Pack.
786.11022	6 Kg	4 pcs.

**WHITE MEDIUM ABRASIVE PASTE**

White medium abrasive paste, hydro compatible. Suitable to remove the painting defects and to polish all kind of mat paints due to weathering (pastel, metallic, pearlescent). Silicon and ammonia free.

Code	Package	Pack.
781.1011	1 Kg	12 pcs.



**BLACK MEDIUM ABRASIVE PASTE**

Black medium abrasive paste, hydro compatible. Thanks to the black colour, is good to polish dark vehicles because is not necessary to mask the plastic parts. Suitable to remove the painting defects and to polis hall kind of mat paints due to weathering (pastel ,metallic, pearlscent). Silicon and ammonia free.

Code	Package	Pack.
781.1013	1 Kg	12 pcs.



**WHITE FINE ABRASIVE-POLISHING PASTE**

Fine wax-based polishing paste for manual or mechine application. For refurbishing weathered paintwork of all types (including metallic paintwork). The paste produces ultra-fine paintwork surfaces. Silicon and ammonia free.

Code	Package	Pack.
781.1010	1 Kg	12 pcs.



**C3 PAINT CLEANER**

Effortless-to-apply cleaning polish for heavily weathered, faded and soiled paint. Also cleans surfaces with a light film of rust. After the use of C3, protect with Polish Riwx.

Code	Package	Pack.
781.1130	1 Kg	6 pcs.







### STAR-WAX

Long-term super gloss. Star-Wax cleans, polishes and conserves well-preserved or buffet paints in one operation. It contains new polymers and selected waxes to provide lasting paint protection. Easy to use and fast drying.

Code	Package	Pack.
<b>782.1110</b>	1 L	6 pcs.
<b>782.1110.5</b>	5 L	4 pcs.
<b>782.3050</b>	500 ml	8 pcs.



### STAR WAX BLACK

Super glossy finish in the long term. Star-wax cleans, polishes and preserves paintwork that is already in good condition in one operation. It contains new types of polymers and choice waxes. These provide long-term protection for paintwork. Recommended for dark vehicles. Easy to use and fast drying.

Code	Package	Pack.
<b>782.1115</b>	1 L	6 pcs.



**NEW  
FORMULA**

### PINK POLISH

Pink polish lends recent or lightly weathered paintwork a deep gloss finish and provides a durable preservation effect, thanks to its excellent polymers. Easy to use and fast drying.

Code	Package	Pack.
<b>782.1091.1</b>	1 L	6 pcs.



### WAX-SHAMPOO

Wash and wax in one operation. Wax-shampoo removes grease and dirt without damaging the paint. At the same time, the surface is preserved and given new gloss by means of wax coating. Ph natural

Code	Package	Pack.
<b>783.2580</b>	6 Kg	4 pcs.
<b>783.3030</b>	450 g	8 pcs.

**SHAMPOO**

For manual car washing. Concentrated car shampoo with good drying effect and pleasant scent.

Code	Package	Pack.
783.2190	5 Kg	4 pcs.



**GLAS-CLAR**

Glass-Clar for effortless and thorough cleaning of all types of glass. Also suitable for use on ceramics and other surfaces. Leaves no residues.

Code	Package	Pack.
783.2150	5 L	4 pcs.
783.2150.20	20 L	1 pcs.



**COCKPIT-SPRAY MAT**

Cleans, revitalises and protects. For cleaning and enhancing car dashboards, vinyl roofs, car seat trims in synthetic leather, plastics of all types, rubber door seals, etc. Protects the treated surfaces from UV rays.

Code	Package	Pack.
783.2485	5 L	4 pcs.
783.3304	300 ml with sprayer	6 pcs.

**FOR INTERIOR**



**MULTI-BRILL**

Multi-Brill is a care, cleaning, refurbishing agent and preservative all in one. For engine preservation and blackening car tyres, dashboards, vinyl roofs, leatherette car setas, plastics of all types and rubber door seals, etc. Provides a non-tacky and non-greasy finish. Do not use near painting areas.

Code	Package	Pack.
783.2980	5 L	4 pcs.
783.3280	500 ml with sprayer	8 pcs.

**FOR EXTERIOR**





### CABIN CLEAN

Powerful cleaner for vehicle interiors. For effective removal of dirt, nicotine, etc. from fabric seats, plastic seats, synthetic leather (not real leather), vehicle roof linings etc.

Code	Package	Pack.
<b>783.2866</b>	5 Kg	4 pcs.
<b>783.2866.20</b>	20 Kg	1 pcs.
<b>783.3320</b>	500 ml with sprayer	8 pcs.



### SIMPLY - CLEAN

Powerful cleaner for vehicle interiors, control devices, steering wheels, upholstery seats, synthetic materials, near leather.

Code	Package	Pack.
<b>783.2872.5</b>	5 Kg	4 pcs.
<b>783.2872.20</b>	20 Kg	1 pcs.



### INSECT-CLEAN

Selected enzymes remove insects. Also removes oil, grease and silicone residue from body parts, windscreens, windows, radiator grilles, headlamp lenses, helmet visors and chrome. Does not attack rubber, paint or plastic parts.

Code	Package	Pack.
<b>783.2220</b>	5 Kg	4 pcs.
<b>783.2220.20</b>	20 Kg	1 pcs.
<b>783.3360</b>	500 ml with sprayer	8 pcs.



### MOTO-QUICK AQUALINE

The highly concentrated engine cleaner can also be used as an exterior cleaner if appropriately diluted. The product has an outstanding cleaning capacity and created a gloss. Moto-Quick Aqualine is self-emulsifying and minimises waste water contamination.

Code	Package	Pack.
<b>783.2100.6</b>	6 Kg	4 pcs.
<b>783.2100.21</b>	21 Kg	1 pcs.

**TAR REMOVER**

For removal of tar and asphalt marks as well as tar-based corrosion inhibitors on original paints, chrome plate or other metal parts.



Code	Package	Pack.
783.2010	5 L	4 pcs.

**ALU- CLEAN**

Strongly acidic wheel cleaner for effortless removal of stubborn dirt such as brake dust, etc. Also suitable for aluminium truck bodies.



Code	Package	Pack.
783.2370	6 Kg	4 pcs.

**RUBBER CLEANER**

For cleaning and blackening of all rubber parts, car tires, mats and side trims. Silicone free.



Code	Package	Pack.
783.2130	5 L	4 pcs.
783.2130.20	20 L	1 pcs.

**TYRE GLOSS - GLOSSY**

New gloss and protection for dull tyres and plastic parts. Economical in use. Long lasting effect, even after 3-4 washes. Do not use on scooter and motorcycles.



Code	Package	Pack.
783.2135	5 L	4 pcs.





### RUST FILM REMOVER

For all effortless removal of rust film on new and used vehicles. Can also be used for trains, trucks and containers.

Code	Package	Pack.
<b>784.2120</b>	5 Kg	4 pcs.



### PARAFFIN PROTECTIVE WAX

Protective wax spray for vehicles, vehicle parts (such as rims) and machines. Protects surfaces against aggressive soiling (such as salt, insects, etc.).

Code	Package	Pack.
<b>784.2460</b>	4,5 Kg	4 pcs.
<b>784.2460.15</b>	15 Kg	1 pcs.



### ANTI-WAX

For effortless dewaxing of wax-protected vehicles. Anti-Wax does not attack paint or rubber and is virtually odourless.

Code	Package	Pack.
<b>784.2430.20</b>	20 L	1 pcs.



**WATERLESS SYSTEM RIWAX**

The system of washing without water for exterior and interior of vehicles.



Approved by **Hertz**



**Waterless** is the system for complete cleaning of vehicles without water. Infact with only 1 product, the cleaner liquid, you can clean all kind of vehicles without water.

**Benefits:**

- Easy to use
- Fast and economic
- 1 single product for cleaning of interior and exterior

- Doesn't dirty
- Respect for the environment
- Suitable for washing vehicles everywhere: into the car showroom, workshop, outdoor.

**Waterless System** is ok for cleaning of:

- Auto - Trucks - Vans - Bus - Moto - Scooter - Byke - Caravan - Boths

Code	Package	Pack.
784.2245.5	5 L	4 pcs.
784.2245.20	20 L	1 pcs.
784.2245.200	Fusto 200 L	1 pcs.



**SPRAY MATIC**

Pressure sprayer with manual charge of 1,5 L.

Code	Package
785.4110	1 pcs.

**BLUE MICROFIBER CLOTH**

For external cleaning.

Code	Package
785.3476	50 pcs.



**CAR DUSTER**

Kit with 2 brushes for preliminary cleaning.

Code	Package
785.4102	1 set

**LIGHT BLUE MICROFIBER CLOTH**

For external drying.

Code	Package
785.3477	50 pcs.



**WASHER**

Manual washing machine for microfiber cloths.

Code	Package
785.5515	1 pcs.



### CONCAVE POLISHING PADS

Polishing pads Ø 240 mm and thickness of 40 mm with contoured edges for works on concave corners. Velcro connection. Available in 3 versions: Hard Blu suitable for mordant abrasive pastes; Medium White suitable for all works with abrasive pastes and polish; Soft Black suitable for finishing works with slightly abrasive polish or polishes.

Code	Description	Size
785.11570-L	Blu duro	Ø 240 x 40 mm
785.11571-L	White medium	Ø 240 x 40 mm
785.11572-L	Black morbido	Ø 240 x 40 mm



### LOW POLISHING PADS

Low polishing pads, smooth surface with blunt edge. Manageable, do not heat and prevent the splashes of product. Velcro connection. Size: Ø 175 mm. Thickness of 30 mm. Available in 3 versions: Hard Blue for polishing with medium and thick abrasive paste; Medium White for polishing with fine abrasive paste and to finish with abrasive polish; Soft Black for mirror finish with polish and protective waxes.

Code	Description	Size
785.11570-M	Blu duro	Ø 175 x 30 mm
785.11571-M	White medium	Ø 175 x 30 mm
785.11572-M	Black morbido	Ø 175 x 30 mm



### HIGH POLISHING PADS

Polishing pads, smooth surface with blunt edge. Velcro connection. Size: Ø 150 mm. Thickness of 50 mm. Available in 3 versions: Medium-Hard Orange for polishing with medium and thick abrasive paste; Medium White for polishing with medium and fine abrasive paste; Soft Black for finishing with polish and protective waxes.

Code	Description	Size	Package
785.5551	Black morbido	Ø 150 x 50 mm	10 pcs.
785.5552	Arancio medium-duro	Ø 150 x 50 mm	10 pcs.
785.5554	White medium	Ø 150 x 50 mm	10 pcs.



### MICROFIBER BONNET

For polishing sponges on orbital polishers. For polishing up. Better absorption, no hologram traces.

Code	Size	Package
785.11575	Ø 170 mm	5 pcs.

**MINI POLISHING PADS**

Mini polishing pads with blunt edge. Velcro connection. Size: Ø 85 mm. Thickness of 30 mm. Available in 2 versions: Hard Blue for polishing with medium and thick abrasive paste; Medium White for polishing with fine abrasive paste and refinishing with abrasive polish.



Code	Description	Size	Package
785.11570-S	Blu duro	Ø 85 x 30 mm	5 pcs.
785.11571-S	White medium	Ø 85 x 30 mm	5 pcs.

**LAMBWOOL DISC**

Polishing out traces from P1200 to P3000 grit sandpaper, better sander polishing, faster, low heat generation. Velcro connection.



Code	Size	Package
785.11576-S	Ø 75 mm	5 pcs.
785.11576-M	Ø 165 mm	5 pcs.
785.11576-L	Ø 200 mm	5 pcs.

**PAD POLISHING**

Blue Pad made of resin with foam rubber support for polishing pads. Thread M14. Velcro connection.



Code	Size
785.5520	Ø 150 mm
785.5522	Ø 175 mm

**ADAPTER**

Flexible and soft adapter to be coupled to the wool special disc to improve the polishing on non-planar areas or to reduce the polishing power. Velcro connection.



Code	Size
785.11577-S	Ø 75 mm
785.11577-M	Ø 150 mm
785.11577-L	Ø 175 mm



### POLISHING CLOTH

Nonwoven breathable cloth, extremely soft and fluffy, suitable for polishing of delicate surfaces. White colour. Pack.: roll of 400 cloths with central extraction.

Code	Description
785.4065	Panno 30x40 cm
785.1150	Supporto a parete



### WATER BLADE

Soft rubber spatula, suitable to remove quickly and perfectly water from all surfaces, without the risk of damage the paint.

Code	Size
785.4058	31X9.5 cm



### CAR-DRY CLOTH

For windows, reflectors, chrome and paint. Extra absorbent, fluff-free, no formation of smears. Well-tolerated with paint, eco-friendly, without softener. Soft and smooth. Machine washable up to 95°C, suitable for drier.

Code	Size	Package
785.4101	48,5x51 cm	10 pcs.



### FRINA-INSECT

Sponge with 1 side with slightly abrasive fiber to remove teh hard dirt.

Code	Size	Package
785.3370	90X155X50 mm	24 pcs.

**DISPENSER**

PE bottle and HDPE sprayers HDPE. With cap or adjustable sprayer. Practical and resistant, suitable for the application of cleaning and polishing products.

Code	Description
785.4009	(A) Jumbo sprayer 1 L
785.4010	(B) Sprayer 1 L
785.4011	(C) Mini sprayer 500 ml
785.4007	(D) Bottle 500 ml



**ELECTRONIC POLISHER MAKITA**

High-quality precision polishing machina. 1200 W, 220 V, 600-3000 U/min.



Code
785.5509

**ELECTRONIC POLISHER RIWAX**

Handy, adjustable, 1300 W, 220 V, 800-2400 R/min.



Code
785.5511

**DUAL ACTION POLISHER RIWAX**

Orbitl polisher of high power (880 W), Dual Action with orbit of 21 mm large diameter. The orbital polisher, compared to conventional rotary polishing machines, prevents the formation of holograms on polished surfaces, without the necessity to remove them with another polishing operation.

**Technical features:**

Voltage: 220-240V AC - 50 Hz  
 Variable speed: 1800-4800 OPM (orbits/minute)  
 Thread: 5/16 “  
 Weight: 2,500 kg ca



Codice
785.5713







### RX 20 SPRAY FINISH

Spray cleaner. Contains selected preservatives. Suitable for use on all surfaces. Cleans without water. Aid for removing polish. Removes fingerprints, protects. Adds new sheen. Quick and easy to use, also suitable for Plexiglass and acrylic glass. Solvent free. VOC 2,0 %.

Code	Package	Pack.
780.1406.05	500 ml with sprayer	8 pcs.



### WAX-POLISH

Cleans and preserves at one and the same time. It removes the oxidized and dull surface gives the black surface its original shine.

Code	Package	Pack.
782.3010	500 g	8 pcs.



### STAR-WAX

Easy to use polish for new and slightly weathered paint surfaces. Cleans, polishes and preserves at one and the same time. Contains new types of polymer and selected waxes to provide durable protection of paintwork.

Code	Package	Pack.
782.3050	500 ml	8 pcs.



### CAR-SHAMPOO

Car shampoo that preserves paint finish and has an excellent cleaning action.

Code	Package	Pack.
783.3025	1000 ml	6 pcs.

**WAX-SHAMPOO**

Washes and waxes at one and the same time. Removes grease and dirt, but does not damage paint. At the same time, it preserves the surface with a wax coating and gives the paintwork a new shine.



Code	Package	Pack.
783.3030	450 g	8 pcs.

**MULTI BRILL**

Multi Brill is a care agent, cleaning agent, refurbishing agent and preservative all in one. For engine preservation and caring for and blackening car tyres, dashboards, vinyl roofs, leatherette car seats, plastics of all types and rubber door seals etc. Provides a non-tacky and non-greasy finish.



Code	Package	Pack.
783.3280	500 ml with sprayer	8 pcs.

**COCKPIT-SPRAY CLASSIC**

Cares for regenerates and preserves surfaces. Protects the surface against UV radiation. Cares for and freshens up car dashboards, vinyl roofs, car seats made of leatherette and all types of plastic and rubber door seals etc.



Code	Package	Pack.
783.3300	300 ml with sprayer	6 pcs.

**COCKPIT-SPRAY MAT**

Cleans and cares without leaving a shiny appearance. Protects surfaces against UV radiation. Prevents sunlight and light from headlights on the windscreen. Achieves an antistatic effect. For a pleasantly fresh cockpit.



Code	Package	Pack.
783.3304	300 ml with sprayer	6 pcs.



### CABIN CLEAN

Powerful, odour-neutralising cleaner for the vehicle interior. Can be used to effectively clean seat upholstery, plastics, leatherette (not genuine leather) and roofliners etc. to remove dirt and nicotine.

Code	Package	Pack.
783.3320	500 ml with sprayer	8 pcs.



### GLASS-CLEAN

For effortless, fast cleaning of glass surfaces on vehicles and in the home. Cleans leaving no streaks and no residue.

Code	Package	Pack.
783.3330	500 ml with sprayer	8 pcs.



### CLEAN-TEX FOAM

For cleaning upholstery and textile trim. Special substances eliminate unpleasant and keep surface clean.

Code	Package	Pack.
783.3340	500 ml	6 pcs.



### INSECT-CLEAN

Selected enzymes remove insects. Also removes oil, grease and silicone residue from body parts, windscreens, windows, radiator grilles, headlamp lenses, helmet visors and chrome. Does not attack rubber, paint or plastic parts.

Code	Package	Pack.
783.3360	500 ml with sprayer	8 pcs.

**WHEEL-CLEANER**

Highly effective cleaner. Removes stubborn dirt from wheels almost instantly.



Code	Package	Pack.
783.3390	500 ml with sprayer	8 pcs.

**BLACK & SHINE**

Contains high-tech rubber care agents. Maintains the tyres sheen and provides protection in the long term for faded tyres and plastic components. Highly concentrated and thus extremely economical. One can suffices for approx. 30 tyres.



Code	Package	Pack.
783.3395	400 ml	6 pcs.

**VITROMAT 1:100**

Highly concentrated windscreen cleaner (without antifreeze) for the car windscreen washer system. Removes oil, grease, silicone and insect residue. Maximum cleaning action, no streaking.



Code	Package	Pack.
784.3240	500 ml	8 pcs.

**VITROCLEAN**

Ready to use cleaner for the windscreen washer system in winter. Cleans and removes silicone oil and grease. Antifreeze action down to - 10°C.



Code	Package	Pack.
784.3146	2000 ml	6 pcs.



### LEATHER-CLEANER

Cleans leather and removes spots and stains such as food stains, lipstick, shoe cream and a great deal more.

Code	Package	Pack.
784.3232	200 ml	6 pcs.



### LEATHER-LOTION

Keeps clean leather soft and supple. It gives the leather back its natural sheen and prolongs the life of the material by many years if used regularly. Cares for feeds the leather and prevents drying out and cracking.

Code	Package	Pack.
784.3233	200 ml	6 pcs.



### LEATHER-SPRAY

Keeps leather soft, supple and water-repellent. CFC free.

Code	Package	Pack.
784.3231	250 ml	6 pcs.



### ICE-EX

It is used to immediately iced-up windscreens and windows. However, it can also be used to prevent ice forming.

Code	Package	Pack.
784.3155	500 ml with sprayer	8 pcs.



**ANTI-FOG**

Clear visibility, prevents misting up of the insides of windscreen and window, helmet visors and spectacles etc.



Code	Package	Pack.
784.3335	200 ml	6 pcs.

**MOTO-SHINE**

It is a care and protective spray for all motorcycles, etc. Provides surfaces with a new gloss and acres for paintwork. Protects and preserves. Water-repellent. Do not treat tyres or gear components with Moto Shine.



Code	Package	Pack.
784.3298	500 ml with sprayer	4 pcs.

**MOTO-CLEANER**

General purpose cleaner for motorcycles etc. with anti-corrosion action. Dissolves and removes all types of dirt, specifically oil and grease.



Code	Package	Pack.
784.3295	500 ml with sprayer	4 pcs.

**SPRING BREEZE**

Odour-neutralizing indoor air freshener for freeing vehicle interiors, carpets and fabrics bad smell. All that remains is a scent experience reminiscent of freshly-laundered clothes SPING BREEZE, a spray that encourages you to drive more slowly.



Code	Package	Pack.
783.3325	200 ml	6 pcs.



### COCKPIT-CLEAN CLASSIC

Wet cloths to protect the surfaces from UV rays. Suitable to cure and refresh dashboards, vinyl roofs, leatherette seats, etc.

Code	Package	Pack.
784.3810	Busta 15 panni	12 pcs.



### LEATHER CLEANER & POLISH

Wet cloths to clean and polish the leather parts of vehicles. It makes the colors brighter and protects the leather.

Code	Package	Pack.
784.3229	Busta 15 panni	12 pcs.



### GLASS-CLEAN FLOW-PACK

Wet cloths for a fast and easy clean of all types of glass. It cleans without leaving lines and residues.

Code	Package	Pack.
784.3504	Busta 15 panni	12 pcs.



### POLISHING CLOTH

Extra soft polishing cloth.

Code	Package	Pack.
785.3365	Busta 15 panni 38x50 cm	6 pcs.

**CAR DUSTER**

Wool brush wool with wooden handle, impregnated with a special resin to capture and hold dust. It can be used countless times. Set contains: 1 large brush of 58 cm and 1 small brush of 37 cm.



Code	Package
785.4102	1 set con 2 spazzole

**MICROFIBER CLOTH**

- Approx. 40x40 cm
- Cleans thoroughly and leaves no streaks
- For interior and exterior use
- Can be used wet or dry



Code	Size
785.5578	40x40 cm

## 2Step SRD™ Sistar Removing Defect System for the fast elimination of paint defects

### What is this?

A practical and simple system with 2 quick operation allows you to:

1. Remove in just 4-5 seconds small defects on new painted surface
2. Rub the signs of the previous operation sanding, without leaving marks or holograms, in about 10 seconds.

### When to use it?

- In all cases in which there are defects of small or medium-size and small sagging
- When there are no excessive defects and should not repaint all the detail
- To avoid disputes on the work due to imperfections or marks on the surface
- To save time and optimize costs

### Why is it worth?

Using only three products and two dedicated tools:

- 1 Mini abrasive disk Ø 35 mm grain P3000 adhesive attachment (cod. 172.0555.3000)
- 1 Mini orbital sander Pneumatic angle (cod. 471.0860)
- 1 Pasta Abrasive Polishing Riwax PX100 (cod. 780.1420)
- 1 corrugated sponge pad Ø 80 mm (cod. 162.0128)
- 1 Mini Polisher Pneumatic orbital sander (cod. 471.0865)



### 1st Step

Eliminate the problem with the **Mini Orbital Sander Sistar** angular and abrasive **Starline Mini Adhesive P3000 Sistar**, spraying water on surface. Operate the tool for about 5 seconds with a cross and circular motion.



### 2nd Step

Pour a few drops of Pasta Abrasive Polishing **Riwax PX100** on **Mini Buffer orange rustication Sistar** and the **Mini orbital polisher Sistar** eliminate signs of sanding and polishing simultaneously with a zig / zag movement for about 10 seconds.

**FAST - PERFECT - PROFESSIONAL**



PAGE 177-190

**DEVILBISS LINE**  
Automotive Refinishing

**DEVILBISS**  
AUTOMOTIVE REFINISHING





**DEVILBISS**  
AUTOMOTIVE REFINISHING

## GTi Pro Lite

A lightweight gun that delivers heavyweight performance. A new lightweight Devilbiss spray gun developed for busy professional painters needing the ultimate in quality finishes. Range of three advanced technology air caps (one HVLP and two High Efficiency) for optimum application performance with the latest solvent and waterborne coatings. All new ergonomic gun body design with even better fit and balance for comfort and control. Three high efficiency fluid tips provide superb versatility across a range of climatic conditions and viscosities. Coaxial, low kick air valve design gives smoother feel for even greater air and paint control for ease of fade-outs and blend-ins. Simplified, user friendly components provide faster, easier cleaning and maintenance.



### Technical features

Inlet air pressure	2.0 bar (29 psi) for Cap TE 10/TE 20 1.75 bar (25 psi) for Cap HV 30
Air consumption	TE110: 265 l/min (9,5 cfm) TE10: 270 l/min (9,5 cfm) TE20: 360 l/min (12,7 cfm) HV30: 460 l/min (16,3 cfm)
Inlet air fitting	1/4" Universal
Weight	446 g (only spray-gun)



**HV30**  
Air cup  
HVLP



**TE10**  
Air cup  
High efficiency



**TE20**  
Air cup  
High efficiency



**T110**  
Air cup  
High efficiency



DGIPRO-504-BAR-K

### GTi Pro Lite

Code examples are as follows: PROLT-GTE10-1213-GD

GTi PRO Lite Gravity Non digital

With air cap TE10 or TE110, TE20, HV30

Part numbers with a '1213' will have a 1.3 fitted to the gun and spare 1.2 tip in the box

Part numbers with a '1314' will have a 1.3 fitted to the gun and spare 1.4 tip in the box

GD Colour Gold or 'BK' for Black or 'BU' for Blue

Code	Description
<b>PROLT-GT110-1213-BK</b>	GTi Pro Lite gravity spray gun kit - anodised in Black 'Quick Clean' & fitted with 1.3mm tip and spare 1.2mm fluid tip, with T110 air cap.
<b>PROLT-GTE20-1314-GD</b>	GTi Pro Lite gravity spray gun kit - anodised in Gold & fitted with 1.3mm tip and spare 1.4mm fluid tip, with TE20 air cap.
<b>PROLT-GHV30-1314-BU</b>	GTi Pro gravity spray gun kit - anodised Gold & fitted with 1.3mm tip and spare 1.2mm fluid tip, with TE20 air cap

## GTi Pro



Building on the heritage of the first GTi gravity models the GTi Pro has now firmly established itself globally as the first choice for the application of all types of water and solvent-borne basecoats. A new generation of larger "Pro" HVLP and Trans-Tech air caps provide unparalleled atomisation for longer, more uniform spray patterns giving perfect colour accuracy in pearlescents and flake lay in metallics and micas. In approval tests with paint company technicians the GTi Pro has consistently met the highest colour match standards to ensure that you get it right, first time, every time. Coupled with performance is precision engineering that optimises control, comfort and balance. The re-profiled trigger and patented, balanced air valve guarantee positive but smooth, "no-kick" operation.

### Technical features

Inlet air pressure	2.0 bar (29 psi) for Cap TE 10/TE 20 1.75 bar (25 psi) for Cap HV 30
Air consumption	TE110: 265 l/min (9,5 cfm) TE10: 270 l/min (9,5 cfm) TE20: 360 l/min (12,7 cfm) HV30: 460 l/min (16,3 cfm)
Inlet air fitting	1/4" Universal
Weight	510 g (only spray-gun)



**HV30**  
Air cup  
HVLP

**TE10**  
Air cup  
High efficiency

**TE20**  
Air cup  
High efficiency

**T110**  
Air cup  
High efficiency



DGIPRO-503-BAR-K

### GTi Pro

Code examples are as follows: PROGTI-GTE10-1314-GD

GTI PRO Gravity Non digital

With air cap TE10 or TE110, TE20, HV30

Part numbers with a '1314' will have a 1.3 fitted to the gun and spare 1.4 tip in the box

Part numbers with a '1213' will have a 1.3 fitted to the gun and spare 1.2 tip in the box

GD Colour Gold or 'BK' for Black or 'BU' for Blue

Code	Description
<b>PROGTI-GT110-1314-BU</b>	GTi Pro gravity spray gun kit - anodised Blue & fitted with 1.3mm tip and spare 1.4mm fluid tip, with T110 air cap
<b>PROGTI-GHV30-1213-BK</b>	GTi Pro gravity spray gun kit - anodised Black 'Quick Clean' & fitted with 1.2mm tip and spare 1.3mm fluid tip, with HV30 air cap
<b>PROGTI-GTE20-1213-GD</b>	GTi Pro gravity spray gun kit - anodised Gold & fitted with 1.3mm tip and spare 1.2mm fluid tip, with TE20 air cap





**PRi Pro Lite**

To strengthen further the Pro Lite family of spray guns we are now very pleased to announce the introduction of the new PRi Pro Lite gravity feed primer spray gun with immediate availability. The new gun replaces the current PRi which is now no longer available. Sharing the lightweight forging and aluminium controls from the GTi Pro Lite the new PRi Pro Lite is now even more comfortable and easier to use for the end user with the smooth control from the GTi Pro Lites low kick air valve.

Suitable for all primers including waterbased materials, surfacers and polyesters the PRi Pro Lite is an essential part of the refinishers tool box.

**PR10 Air Cap and Fluid Tips**

We've renamed the current P1 air to the PR10 High Efficiency air cap which delivers fine atomisation with a well formed large and uniform spray pattern making it ideal for primer coverage. There are 5 new fluid tips available to fit the PRi Pro Lite including a 1.4, 1.6, 1.8, 2.0 and 2.5 which can apply virtually all primers, surfacers and fillers and polyesters. The 2.5 will suit polyesters while the 1.8 and 2.0mm will suit high build fillers. The 1.4 and 1.6 are ideal for etch or wash primers, wet-on-wet (non-sand) and the latest compliant primers.

**Technical features**

Inlet air pressure	2.0 bar (29 psi)
Air consumption	300 l/min (10.6 cfm)
Inlet air fitting	1/4" Universal
Capacity cup	560 mls
Weight	445 g (only spray-gun)

Codice	Description
<b>PRILT-GPR10-14</b>	Gravity Gun & Cup - PR10 Air Cap & No. 14 Fluid Tip
<b>PRILT-GPR10-16</b>	Gravity Gun & Cup - PR10 Air Cap & No. 16 Fluid Tip
<b>PRILT-GPR10-18</b>	Gravity Gun & Cup - PR10 Air Cap & No. 18 Fluid Tip
<b>PRILT-GPR10-20</b>	Gravity Gun & Cup - PR10 Air Cap & No. 20 Fluid Tip
<b>PRILT-GPR10-25</b>	Gravity Gun & Cup - PR10 Air Cap & No. 25 Fluid Tip



### SRI Pro Lite

Leading edge i-system Pro spray gun technology brings new levels of performance to MICRO, SMART and professional spot repair Lightweight, precision engineered, small scale spray gun, ensuring excellent control for superb feathering, perfect for localised detail or medium area work. Uniform, evenly dispersed spray patterns from the advanced technology High Efficiency and HVLP air caps. Renowned DeVilbiss fit, feel and balance is ensured by the ergonomically designed, anodised forged aluminium gun body. A comprehensive range of air cap, fluid tip and needle combinations ensures perfect atomisation of all types of solvent or waterborne materials.

#### Technical features

Inlet air pressure	2.0 bar (30 psi) for Cap HV5 e TE5 1.0 bar (15 psi) for Cap MC1 and RS1
Air consumption	HV5: 135 l/min (4,8 cfm) TE5: 100 l/min (3,5 cfm) MC1: 50 l/min (1,8 cfm) - RS1: 55 l/min
Inlet air fitting	1/4"
Weight	455 g
Cup capacity	125 ml

**NEW**



RS1 - Air cup round jet



TE5 Air cup High efficiency



HV5 Air cup HVLP



MC1 Air cup micro High efficiency

Code	Description
<b>810.SRIPROL-HV5-**</b>	SRI PRO LITE HVLP Air cap HV5, nozzle Ø ** (0,8-1,0-1,2-1,4) mm
<b>810.SRIPROL-TE5-**</b>	SRI PRO LITE High efficiency with Air cap TE5, nozzle Ø ** (0,8-1,0-1,2-1,4) mm
<b>810.SRIPROL-MC1-06</b>	SRI PRO LITE High efficiency with Air cap Micro MC1, nozzle Ø 0,6 mm

### FLG-5



General purpose compliant spray gun for a wide range of refinish paints and coatings. Operates with unique and efficient DeVilbiss Trans-Tech® Atomisation Technology. Ergonomically shaped gun handle for positive grip and comfort. Smooth action trigger with exceptionally light pull for fatigue free operation. Ultra lightweight but strong, cast aluminium gun body. Full controls of pattern shape, fluid flow rate and air inlet pressure. Precision engineered brass air cap and stainless steel fluid tips. Choice of gravity or suction models with large capacity cups.

#### Technical features

Inlet air pressure	2.0 bar (29 psi)
Air consumption	277 l/min (9,8 cfm)
Inlet air fitting	1/4" Universal
Weight	Gravity 642 g - Suction 934 g
Cup capacity	Gravity 560 ml - Suction 1140 ml



Code	Description
<b>810.FLG-G5-**</b>	FLG-G5 con Cap N. 5 Trans-Tech®, nozzle Ø ** (1,4-1,8) mm - il Ø 2,0 mm available only as spare part
<b>810.FLG-S5-18</b>	FLG-S5 Suction for Cap N. 5 Trans-Tech®, nozzle Ø 1,8 mm
<b>810.FLG-P5-14</b>	FLG-P5 Pressure for Cap N. 5 Trans-Tech®, nozzle Ø 1,4 mm



FLG-S5

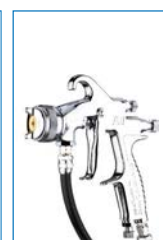

FLG-P5





**DEVILBISS**  
AUTOMOTIVE REFINISHING

**STARTINGLINE**

### SLG-620

SLG-620 is suitable for a wide range of automotive refinish paints. The lightweight and strong gun body has an ergonomically shaped handle for positive grip and comfort with a smooth action trigger and accurate controls for fluid flow and pattern shape. The precision engineered brass air cap provides excellent atomisation of the most popular, conventional automotive refinish materials. Fitted with a tough mylon 550ml cup, the SLG spray gun kit also includes a removable paint filter, a cleaning brush and universal spanner for easy cleaning and maintenance.



#### Technical features

Inlet air pressure	2.0 bar (29 psi)
Air consumption	250 l/min (8,8 cfm)
Inlet air fitting	1/4"
Weight	480 g (spray-gun)

Code	Description
<b>810.SLG-620-13</b>	SLG-620 Kit gravity spray gun with cup and fluid tip Ø 1,3 mm
<b>810.SLG-620-18</b>	SLG-620 Kit gravity spray gun with cup and fluid tip Ø 1,8 mm
<b>810.SLG-620-25</b>	SLG-620 Kit gravity spray gun with cup and fluid tip Ø 2,5 mm

### GFG Pro

Totally redesigned GFG gun for professional use. Renowned Devilbiss atomisation quality and even paint distribution. Utilises new air valve design for ultra smooth triggering and control. Rugged drop forged body with anodised finish for protection. A choice of two advanced technology air caps to suit solids and metallics. Three fluid tip sizes for varying viscosities and control preferences. New, more ergonomic gun body with improved fit, feel, comfort and control. Faster, easier maintenance from user-friendly fittings and adjustments.



#### Technical features

Inlet air pressure	C1: 2.5 - 3.0 bar (30 - 45 psi) C2: 2.5 - 4.0 bar (30 - 60 psi)
Air consumption	C1: 300 l/min C2: 305 l/min
Inlet air fitting	1/4"
Weight	768 g



C1 - Cap



C2 - Cap

Code	Description
<b>810.GFGPRO-C1-**</b>	GFG PRO CONVENZIONALE for Air cap C1, nozzle Ø ** (1,4-1,6) mm
<b>810.GFGPRO-C2-**</b>	GFG PRO CONVENZIONALE for Air cap C2, nozzle Ø ** (1,4-1,6-1,8) mm



**GTi Pro Lite Suction and Pressure**



The new lightweight gun but redesigned for pressure feed duty. All new ergonomic gun body design with even better fit and balance for comfort and control. A range of pressure & suction nozzle sizes for varying viscosities and control preferences. Five compliant air cap choices to suit all materials and coatings. Utilises new coaxial air valve design for ultra-smooth triggering and control. Renowned DeVilbiss atomisation quality and even paint distribution. Faster, easier maintenance from user-friendly fittings and adjustments.

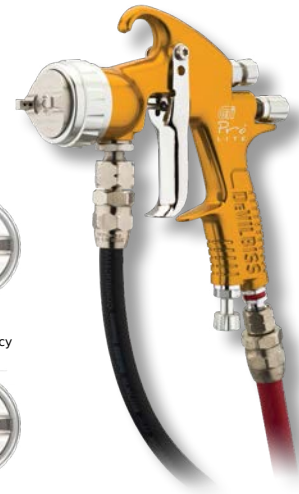

**Technical features**

Inlet air pressure	2.0 bar (29 psi)
Air consumption	TE10: 270 l/min (9,5 cfm) TE20: 360 l/min (12,7 cfm) TE30: 365 l/min (12,9 cfm) TE40: 350 l/min (12,4 cfm)
Inlet air fitting	1/4" BSP / NPS
Inlet fluid fitting	3/8" BSP / NPS
Weight	490 g
Cup capacity	1000 ml

Code	Description
<b>810.PROSL-TE10-**</b>	GTI PRO LITE Suction High efficiency with Air cap TE10, nozzle Ø ** (1,6-1,8-2,0) mm
<b>810.PROSL-TE20-**</b>	GTI PRO LITE Suction High efficiency with Air cap TE20, nozzle Ø ** (1,6-1,8-2,0) mm
<b>810.PROPL-TE10-**</b>	GTI PRO LITE Pressure High efficiency with Air cap TE10, nozzle Ø ** (0,85-1,0-1,2-1,4-1,6-1,8) mm
<b>810.PROPL-TE20-**</b>	GTI PRO LITE Pressure High efficiency with Air cap TE20, nozzle Ø ** (0,85-1,0-1,2-1,4-1,8) mm
<b>810.PROPL-TE30-**</b>	GTI PRO LITE Pressure High efficiency with Air cap TE30, nozzle Ø ** (1,0-1,2-1,4-1,6-2,0) mm
<b>810.PROPL-TE40-**</b>	GTI PRO LITE Pressure High efficiency with Air cap TE40, nozzle Ø ** (0,85-1,0-1,2-1,4-1,8) mm



**GTi Pro Suction and Pressure**



Totally redesigned GTi Pro gun for suction feed duty. New, more ergonomic gun body with improved fit, feel, comfort and controls. Four compliant air cap choices to suit solids, metallics, bases and clears. A range of suction nozzle sizes for varying viscosities and control preferences. Utilises new air valve design for ultra smooth triggering and control. Renowned DeVilbiss atomisation quality and even paint distribution. Faster, easier maintenance from user-friendly fittings and adjustments. Rugged drop forged body with anodised finish for protection.



**Technical features**

Inlet air pressure	2.0 bar (30 psi)
Air consumption	H1: 450 l/min (16 cfm) T1: 280 l/min (10 cfm) T2: 350 l/min (12 cfm) T4: 330 l/min (11,7 cfm)
Inlet air fitting	1/4" BSP / NPS
Inlet fluid fitting	3/8" BSP / NPS
Weight	650 g
Cup capacity	1000 ml

Code	Description
<b>810.GTISPRO-H1-**</b>	GTI PRO Suction HVLP con Air cap H1, nozzle Ø ** (1,6-1,8-2,0) mm
<b>810.GTISPRO-T1-**</b>	GTI PRO Suction High efficiency with Air cap T1, nozzle Ø ** (1,6-1,8-2,0) mm
<b>810.GTISPRO-T2-**</b>	GTI PRO Suction High efficiency with Air cap T2, nozzle Ø ** (1,6-1,8) mm
<b>810.GTIPPRO-H1-**</b>	GTI PRO Pressure HVLP con Air cap H1, nozzle Ø ** (0,85-1,0-1,2-1,4-1,8) mm
<b>810.GTIPPRO-T1-**</b>	GTI PRO Pressure High efficiency with Air cap T1, nozzle Ø ** (0,85-1,0-1,2-1,4-1,6-1,8) mm
<b>810.GTIPPRO-T2-**</b>	GTI PRO Pressure High efficiency with Air cap T2, nozzle Ø ** (0,85-1,0-1,2-1,4-1,6-1,8-2,0) mm
<b>810.GTIPPRO-T4-**</b>	GTI PRO Pressure High efficiency with Air cap T4, nozzle Ø ** (0,85-1,0-1,2-1,4-1,6-1,8-2,0) mm



**JGA Pro Suction and Pressure**

Totally redesigned JGA gun for professional use. Renowned Devilbiss atomisation quality and even paint distribution. Utilises new air valve design for ultra smooth triggering and control. Rugged drop forged body with anodised finish for protection. A choice of two advanced technology air caps to suit solids and metallics. Three fluid tip sizes for varying viscosities and control preferences. New, more ergonomic gun body with improved fit, feel, comfort and control. Faster, easier maintenance from user-friendly fittings and adjustments.

**Technical features**

Inlet air pressure	2.5 - 3,0 bar (30 - 45 psi) for Cap C1 e C2 2.5 - 4,0 bar (30 - 58 psi) for Cap C3
Air consumption	C1: 300 l/min (10,6 cfm) C2: 305 l/min (12,8 cfm) C3: 410 l/min (14,5 cfm)
Inlet air fitting	1/4"
Inlet fluid fitting	3/8"
Weight	650 g
Cup capacity	1000 ml



Code	Description
<b>810.JGASPRO-C1-**</b>	JGA PRO Conventional Suction with Air cap C1, nozzle Ø ** (1,4-1,6-1,8) mm
<b>810.JGASPRO-C2-**</b>	JGA PRO Conventional Suction with Air cap C2, nozzle Ø ** (1,4-1,6-1,8) mm
<b>810.JGAPPRO-C1-**</b>	JGA PRO Conventional Pressure with Air cap C1, nozzle Ø ** (0,85-1,0-1,2-1,4-1,6-1,8) mm
<b>810.JGAPPRO-C2-**</b>	JGA PRO Conventional Pressure with Air cap C2, nozzle Ø ** (0,85-1,2-1,4-1,6-1,8) mm
<b>810.JGAPPRO-C3-**</b>	JGA PRO Conventional Pressure with Air cap C3, nozzle Ø ** (0,85-1,0-1,2-1,4-1,6-1,8) mm

**KBII 2.3 LITRE REMOTE CUP**

- 2.3 litre capacity - greater area coverage, less refills.
- Aluminium or stainless steel options (for waterbase materials).
- Familiar gun grip handle plus belt hook for operator convenience.
- At the job controls with lid mounted pressure gauge.
- Available complete with short cup to gun air and fluid hoses.

**Technical features**

Thread connection of input and output air	1/4" BSP (M)
Output connection of liquid	3/8" BSP (M)
Max pressure	2,1 Bar (30 psi)
Max air pressure	8,6 bar (125 psi)
Height	183 mm
Weight (without cables)	1,76 kg
Cup capacity	2,3 litri



KK-5051

Code	Description
<b>815.KB-522</b>	KBII Tank under pressure - aluminium 2,3 L without air and paint tubes
<b>815.KB-522-SS</b>	KBII Tank under pressure - stainless steel 2,3 L without air and paint tubes
<b>815.KB-622</b>	KBII Tank under pressure - aluminium 2,3 L with air and paint tubes
<b>815.H-7501HA-1.2</b>	Flexible air tube Red Ø 8 mm (5/16") x 1,2 m with universal fitting 1/4" BSP
<b>815.H-7503HA-1.45</b>	Flexible air tube Black Ø 6 mm (1/4") x 1,45 m with universal fitting 3/8" BSP
<b>815.KK-5051</b>	Disposable plastic bags for KBII with topping - Pack. 20 bags
<b>815.GA-355</b>	Manometer spare part 0-2 BAR (0-30 psi) for KBII
<b>815.KB-422</b>	Aluminium tank spare part for KB-522 E KB-622
<b>815.KB-442</b>	Stainless steel tank spare part for KB-522-SS
<b>815.SLING-KBII</b>	Harness for KBII

Compressed air is the lifeblood of every car-body shops and manage it effectively is very important for the safety of operator, for an efficient production process and for a finish of high quality. The products of the range of regulators for air filters **DVFR DeVilbiss** are manufactured with engineering plastics materials very resistant used in the construction of the bodies of filters, which guarantees a total resistance to solvents while the rolling diaphragm provides optimum air flow and precision control.



### DVFR-8 Filter Regulator Coalescer unit with Activated Carbon element

A compact compressed air Regulator, Filter and Coalescer unit suitable for 1 or 2 operators. The unit is suitable for use with the Respiratory Personal Equipment such as the Devilbiss Air Visor and Half Masks kits.

**Filter** - Incoming air is rotated by a centrifuge unit to remove the heaviest liquid and solid particles. The remaining solid particles are collected by porous bronze filter to 5µm. The accumulated liquid can be drained using the plug in the base of the bowl.

**Regulator** - This allows the input pressure to be reduced to a stable output pressure following initial filtering.

**Coalescer** - This removes the smallest amounts of liquids and solids down to 0.01µm. The liquid droplets are captured on micro fibres, these form large droplets and collect in the bowl which can be drained using the plug at the base of the bowl.

**Activated Carbon:** This element filters in a similar way to the Coalescer, but will remove oil carry over to 0.003 ppm.

**Shut of valves** - Each of the 3 outlets can be isolated independantly.



Code

811.DVFR-8

### DVFR-2 Filter Regulator Coalescer



A compact compressed air Regulator, Filter and Coalescer unit suitable for 1 or 2 operators. The unit is suitable for use with Respiratory Personal Equipment such as the DeVilbiss Air Visor and Half Masks kits.

**Filter** - Incoming air is rotated by a centrifuge unit to remove the heaviest liquid and solid particles. The remaining solid particles are collected by porous bronze filter to 5µm. The accumulated liquid can be drained using the plug in the base of the bowl.

**Regulator** - This allows the input pressure to be reduced to a stable output pressure following initial filterin.

**Coalescer** - This removes the smallest amounts of liquids and solids down to 0.01µm. The liquid droplets are captured on micro fibres, these form large droplets and collect in the bowl which can be drained using the plug at the base of the bowl.

**Shut of valves** - Each of the 3 outlets can be isolated independantly.



Code

811.DVFR-2



**DVFR-1**  
**Air Filter Regulator**

A compact Air Filter Regulator suitable for 1 or 2 operators, designed to remove entrained dirt, liquid oil and water from flowing compressed air, and to regulate the air pressure to enable air using devices to be operated. Regulator is a self relieving design that senses over-pressure at the regulated outlets and vents excess pressure to atmosphere. The rolling diaphragm improves pressure sensitivity adjusting the valve for fluctuating airflows and pressures.

**Technical features**

Inlet air thread	1/2" BSP (F)
Outlet air (sphere valves)	1/4" BSP (M)
Capacity (Max. air jet)	3500 l/min (124 cfm)
Max. inlet air pressure	13 bar (189 psi)
Max. outlet air pressure	0-8 bar (0-116 psi)
Air filtering up to	5 microns
Max. decrease pressure	5% of inlet pressure

**Code**
**811.DVFR-1**
**FLRC-1**  
**Air filter and coalescing filter.**

The filtering system necessary when using paints for car refinish. Its use is required when using a respiratory protection device powered with compressed air. With pressure regulator and analogical manometer.

**Technical features**

Inlet air thread	3/8" BSP (F)
Outlet air (sphere valves)	1/4" BSP (M)
Capacity (Max. air jet)	2000 l/min (70 cfm) a 7 bar
Max. inlet air pressure	18 bar
Max. outlet air pressure	0-8 bar
Air filtering up to	0,01 microns (suitable value for breathing air)
Max. decrease pressure	1/2 bar

Code	Description
<b>811.FLRC-1</b>	Air regulator
<b>811.9450102</b>	Filter spare part for FLRC and FLRCAC
<b>811.AC-12</b>	Coalescent filter spare part for FLRC and FLRCAC



### FLRCAC-1

**Air filter, coalescing filter and activated carbon filter.**

The most complete filter group for use in spraying booths with a water-based paint for car refinish. Its use is required when using a respiratory protection device powered with compressed air. With pressure regulator and analogical manometer.

#### Technical features

Inlet air thread	3/8" BSP (F)
Outlet air (sphere valves)	1/4" BSP (M)
Capacity (Max. air jet)	2000 l/min (70 cfm) a 7 bar
Max. inlet air pressure	18 bar
Max. outlet air pressure	0-8 bar
Air filtering up to	0,01 microns (suitable value for breathing air)
Max. decrease pressure	½ bar



Code	Description
<b>811.FLRCAC-1</b>	Air regulator
<b>811.9450102</b>	Filter spare part for FLRC e FLRCAC
<b>811.AC-12</b>	Coalescent filter spare part for FLRC e FLRCAC
<b>811.XA-12</b>	ctivated carbon spare part for FLRCAC

### DMG-501 AIR DRYER



**Versatile pneumatic system to speed up the drying process of water-based paints.**

A versatile system to speed up the drying process. **The DMG guns multiply for 7 their capacity of suction to attract large volumes of air.** A adjustable stand ensures full flexibility of the drying device. Solvent resistant for the cleaning of machines for washing guns. The DMG guns are equipped with filters for foreign aspirated particles and the stop valves.

#### Technical features

Max inlet pressure	7 bar
Typical Air consumption	325 litre/min @ 3,5 bar
Inlet air fitting	1/4" Universal
Weight	470 g



Input filter dryer

Code	Description
<b>811.DMG-501-K</b>	DMG-501 - Air dryer gun with filter
<b>811.DMG-520-K</b>	DMG-520 - Air dryer stand for 2 guns DMG-501-K
<b>811.DMG-5-K3</b>	Dryer inlet filters - Pack. 3 pcs.





**DEVILBISS**  
AUTOMOTIVE REFINISHING



DGIPRO-503-BAR-K  
DGIPRO-504-BAR-K

### DGi PRO POD

The DGi Pro Pod digital pressure gauge is the natural development of the digital pressure gauge DGi Pro, with the difference that it is designed to be mounted on the top of the spray gun. In this way it can be adjusted and seen clearly by the operator, even if he is left-handed.



Code	Description
<b>811.DGIPRO-503-BAR-K</b>	DGI PRO POD - Digital manometers for spray-gun GTI PRO with outlet air regulator
<b>811.DGIPRO-504-BAR-K</b>	DGI PRO POD - Digital manometers for spray-gun GTI PRO LITE with outlet air regulator

### DIGITAL ANALOGICAL PRESSURE GAUGE

Pressure gauge to adjust and control the pressure of inlet air into the spray gun. Comfortable adjustment back knob also for left-handers. Calibrated up to a pressure of 10 bar (145 psi). Universal connection 1/4" BSP. Display Ø 35 mm. Weight 158 g.



Code
<b>811.HAV-501-B</b>



**Nylon bowl** with anti-drop lid for gravity spray-guns.

**GFC-501** (568 ml)  
**SRI-510** (125 ml)



**1L Cup** for suction spray-gun with anti-drop lid.

**KR-566-1-B** (Complete)  
**KR-466-K** (Only cup)



**Air Filter**

- Air Filter
- Highly effective, retains water, oil and various impurities
- Excellent resistance to solvents
- Universal connection 1/4 "

**HAF-507-K12**  
(Package da 12 filters)

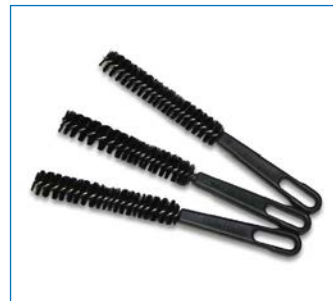

**Brushes** for all cleaning operations of spray-guns.

**4900-5-1-K3**  
(Pack of 3 pcs.)



**Rapid and swivel fittings** with connection 1/4" (F)

**MPV-60-K3**



**Cleaning and maintenance kit.**

It contains everything you need to clean and maintain in a perfect efficiency spray-guns.

**KK-4584**



**Repair and maintenance kit.**

for GTi PRO, SRi PRO, PRi PRO, GPi, GFG PRO, JGA PRO

**PRO-415-1**

for GTi PRO LITE

**PRO-470**



**Filters** for gravity spray-guns.

**KGP-5-K5**  
(Pack of 5 filters)



Purpose made hoses and connectors for the spray industry with conductive outer cover.

### AIR AND FLUID HOSES AND CONNECTORS (LOW PRESSURE)

Binks, DeVilbiss and Ransburg hoses and connectors are purpose made for the spray finishing industry. The use of the best and most dependable air and fluid hoses are vital to all finishing facilities to maintain optimum production levels with the minimum of maintenance downtime. By choosing Binks, DeVilbiss and Ransburg hoses and connectors you are assuring that your spray application equipment receives air and fluids in the best possible condition at the specified pressures and volumes.

Binks, DeVilbiss and Ransburg hoses and connectors are manufactured to the highest quality to maintain engineering tolerances for maximum performance, durability and working life.

- Suitable for all low pressure finishing applications
- Approved for most spray fluids
- Hoses include a conductive outer cover to comply with European ATEX & CE legislation
- Smooth outer cover ensures easy cleaning
- Flexible and manoeuvrable for decreased operator fatigue
- Hoses have excellent chemical compatibility
- Three piece reusable hose connectors (brass plated)
- Air & Fluid hose available per metre or delivered on 150m hose reels.
- Wide range of BSP & NPS threaded connectors.



150m hose reels are available.

Choose hoses and connector part numbers from this specification chart:

Hose Pt No.	Description	Type	Bore size mm	Hose cover	Inner bore	Conductive	ATEX/CE	Max Working Pressure
H-7501	5/16" Bore AIR HOSE Red rubber	AIR	8	EPDM	EPDM	✓	✓	17 bar (250 psi)
H-7502	3/8" Bore AIR HOSE Red Rubber	AIR	9.5	EPDM	EPDM	✓	✓	17 bar (250 psi)
H-7503	1/4" Bore FLUID HOSE Black	FLUID	6	Nitrile	Nylon	✓	✓	34 bar (500 psi)
H-7504	3/8" Bore FLUID HOSE Black	FLUID	9.5	Nitrile	Nylon	✓	✓	34 bar (500 psi)
H-7501-150M	5/16" Bore Air Red Rubber (150M reel)	AIR (BULK)	8	EPDM	EPDM	✓	✓	17 bar (250 psi)
H-7502-150M	3/8" Bore Air Red Rubber (150M reel)	AIR (BULK)	9.5	EPDM	EPDM	✓	✓	17 bar (250 psi)
H-7503-150M	1/4" Bore Fluid Black (150M reel)	FLUID (BULK)	6	Nitrile	Nylon	✓	✓	34 bar (500 psi)
H-7504-150M	3/8" Bore Fluid Black (150M reel)	FLUID (BULK)	9.5	Nitrile	Nylon	✓	✓	34 bar (500 psi)

EPDM is (Ethylene Propylene Diene Monomer) rubber

#### 3 piece Re-usable Connections

Part no.	Bore	Connector
PA-HC-4523	1/4" (6 mm)	1/4" BSP
PA-HC-4527	5/16" (8 mm)	1/4" BSP
PA-HC-4528	3/8" (9.5 mm)	1/4" BSP
PA-HC-4543	1/4" (6 mm)	3/8" BSP
PA-HC-4548	3/8" (9.5 mm)	3/8" BSP
P-HC-4523	1/4" (6 mm)	1/4" NPS
P-HC-4527	5/16" (8 mm)	1/4" NPS
P-HC-4528	3/8" (9.5 mm)	3/8" NPS
P-HC-4543	1/4" (6 mm)	3/8" NPS
P-HC-4548	3/8" (9.5 mm)	3/8" NPS

#### High Pressure Hose Assemblies (Airless)

Hose connectors: 1/4" NPS

Length	Bore	Pressure max.	Part no.
1m	3/16"	350 bar	H-5811
7.5m	3/16"	350 bar	H-5813
7.5m	1/4"	310 bar	H-5818



The above connectors are three piece re-usable (Plated brass)



## WOULD YOU LIKE TO BE OUR PARTNER?

If you want to be a member of a modern and young trading organization, leader in Italy in the Car Refinish field and introduced in more than 20 foreign countries, contact our Sales Export Department at the following numbers:

**Phone:** (+39) 0362-36.73.50 - **Fax:** (+39) 0362-36.73.52 - **Or send your request to:** [export@sistar.it](mailto:export@sistar.it)



## EST-CE-QUE TU VEUX DEVENIR NOTRE PARTENAIRE?

Si tu veux faire partie d'une jeune et moderne organisation commerciale, leader en Italie du marché du Car Refinish et présente dans plus de 20 pays dans le monde entier contactez s'il vous plaît:

**Phone:** (+39) 0362-36.73.50 - **Fax:** (+39) 0362-36.73.52 - **Ou bien adressez une requête à:** [export@sistar.it](mailto:export@sistar.it)



## SIND SIE INTERESSIERT UNSER PARTNER ZU WERDEN?

Wenn Sie Teile unserer jungen und modernen Handelsorganisation - dem Leader in Italien in Sachen Autoaufbereitung - mit Partnern in 20 verschiedenen Ländern, so kontaktieren Sie unsere Verkaufs-, beziehungsweise Exportabteilung:

**Telefon:** (+39) 0362-36.73.50 - **Fax:** (+39) 0362-36.73.52 - **Oder mailen Sie Ihre Anfragen an:** [export@sistar.it](mailto:export@sistar.it)



## USTED QUIERE ESTAR CON NOSOTROS?

Si deseas formar parte de una moderna y joven empresa comercial, que es líder en Italia en el sector del Car Refinish y que es presente en más de 20 países del mundo, ponete en contacto con nuestro Sales Export Department por medium de los numeros que siguen:

**Teléfono:** (+39) 0362-36.73.50 - **Fax:** (+39) 0362-36.73.52 - **O envias tu petición a:** [export@sistar.it](mailto:export@sistar.it)



## ХОТИТЕ СТАТЬ НАШИМ ПАРТНЕРОМ?

Если вы хотите быть партнером молодой, современной торговой компании-лидера на итальянском рынке материалов для кузовного ремонта и представленной более чем в 20 странах, свяжитесь с нашим отделом экспортных продаж по следующим телефонам:

**тел:** (+39) 0362-36.73.50 - **факс:** (+39) 0362-36.73.52 - **или пошлите запрос по электронной почте:** [export@sistar.it](mailto:export@sistar.it)



## VUOI ESSERE NOSTRO PARTNER?

Se vuoi far parte di una moderna e giovane organizzazione commerciale, leader in Italia nel settore del Car Refinish e presente nel mondo in oltre 20 paesi, contatta il nostro Sales Export Department ai seguenti numeri:

**Telefono:** (+39) 0362-36.73.50 - **Fax:** (+39) 0362-36.73.52 - **Oppure invia una tua richiesta a:** [export@sistar.it](mailto:export@sistar.it)

The features and products shown may be subject to change without notice. The informations contained in this catalogue are provided for guide and in good faith. They do not imply our responsibility in consideration of many variables that can affect the proper operation and performance of the products.

Aux caractéristiques et aux produits représentés peuvent être apporté des modifications sans aucun préavis. Les renseignements contenus dans ce catalogue sont fournies à titre d'exemple et en toute bonne foi. Par conséquent, cela n'implique pas notre responsabilité en considération des plusieurs variables qui peuvent influencer le correct emploi et les prestations des produits.

Die Ausführungen in unseren Unterlagen dienen der anwendungstechnischen Unterweisung uns sind nach bestem Wissen zusammengestellt. Eine Verbindlichkeit kann hieraus jedoch nicht hergeleitet werden. Produktänderungen vorbehalten.

Los productos que están aquí pueden sufrir algunas modificaciones también sin aviso. Las informaciones que están aquí son providas como indicación y en buena fe; después ellas no implican nuestra responsabilidad también en consideración de las muchas variables que pueden influir el correcto empleo y las prestaciones de los productos.

Представленные здесь продукты и их характеристики могут быть изменены в любое время без предварительного уведомления. Информация, присутствующая в данном каталоге, является индикативной, и не содержит каких либо гарантий и/или обязательств.

Le caratteristiche e i prodotti presentati possono essere soggetti a modifiche anche without obbligo di preavviso. Le informazioni contenute in questo catalogo sono fornite a titolo indicativo e in buona fede. Non implicano quindi la nostra responsabilità anche in considerazione delle molteplici variabili che possono influenzare il corretto utilizzo e le prestazioni dei prodotti.

